

GRASSLAND PRO HARROW

GP 600 M2

OPERATING MANUAL



PLEASE READ CAREFULLY BEFORE INITIAL OPERATION

Translation of the original operating manual

Version: 2.3 en-US; item number: 00602-3-776



TABLE OF CONTENTS

1	EC DECLARATION OF CONFORMITY	4
2	UK CONFORMITY ASSESSED	5
3	IDENTIFICATION OF THE DEVICE	6
4	SERVICE	6
5	WARRANTY	7
5.1	Warranty activation	7
6	SAFETY INSTRUCTIONS	7
6.1	Intended use	7
6.2	General safety information and accident prevention regulations	8
6.3	Attached implements	10
6.4	Hydraulic system.....	10
6.5	Maintenance	11
6.6	Tires.....	11
6.6.1	Load index and speed index	12
6.7	Attached seeders	12
6.7.1	Filling the seeder.....	12
6.8	Danger areas	12
6.8.1	Danger areas in implement operation	13
6.8.2	Danger areas when folding and unfolding	14
6.9	Residual hazards	14
6.9.1	Danger arising from mechanical systems.....	14
6.9.2	Danger arising from hydraulic systems	14
6.9.3	Dangers arising from operation	15
7	INFORMATION SIGNS / HAZARD LABELS	15
7.1	Information signs.....	15
7.2	Hazard labels	17
7.3	Placement of the hazard labels and other markings	18
8	OPERATING MANUAL	19
8.1	Structure and mode of operation.....	19
8.2	Attachment and detachment of the implement	20
8.2.1	General instructions	20
8.2.2	Parking brake.....	20
8.2.3	Coupling	20
8.2.4	Uncoupling.....	21
8.3	Unfolding from transport position to work position	22
8.4	Folding from work position into transport position.....	23
8.5	Working position and adjusting the working depth.....	23
8.5.1	Depth adjustment / drawbar adjustment.....	23
8.5.2	Adjusting the series of holes	24
8.6	Using specific tools	24
8.7	levelling plate	24
8.8	Coupling and uncoupling the roller	25
8.9	Folding lock.....	26
8.10	Turning on the headland	27
8.10.1	Turning with roller	27
8.10.2	Turning with chassis	27
8.11	Loading and unloading on a low-bed trailer	27

9	ASSISTANCE FOR FAULTS	28
9.1	Procedure for faults or errors	28
10	MAINTENANCE AND CARE	28
10.1	General maintenance instructions.....	28
10.2	Instructions for regular maintenance	28
10.3	Replacing the tines	29
10.4	Tine safety/	29
10.5	Lubrication schedule	29
10.6	Repair and corrective maintenance.....	31
11	INFORMATION ON NATURE CONSERVATION AND ENVIRONMENTAL PROTECTION	31
12	TECHNICAL DATA	32
13	POSSIBLE COMBINATIONS WITH A PNEUMATIC SEEDER	33
14	ROAD TRANSPORT	33
14.1	Transport on public roads (general instructions).....	33
15	LIGHTING CIRCUIT DIAGRAM	35
16	DECOMMISSIONING, STORAGE, AND DISPOSAL	35
16.1	Decommissioning the implement	35
16.2	Storing the implement	35
16.3	Disposal	36
17	CROP CULTIVATION TIPS FOR USE OF THE GRASSLAND PRO HARROW	36
18	ACCESSORIES	37
18.1	Equipment kit for operation on public traffic areas.....	37
18.1.1	Compressed air system	37
18.1.2	Wheel chocks	39
18.1.3	Tine sections cover	39
18.1.4	Lighting with warning signs (both sides)	39
18.1.5	Mudguard.....	40
18.1.6	Anti-theft device	40
18.2	Mounting kit for PS 200 to PS 500	40
18.3	Dispersion plate installation	40
18.4	Mounting kit for PS 800.....	40
18.5	platform kit	41
18.6	Changeover valve for operating two hydraulic functions.....	41
18.7	Toolbox.....	41
18.8	Sensor set: GPSa + linkage sensor	41
18.9	Mounting kit for feeler wheels.....	42
19	SPARE PARTS	43
20	INDEX	43

1 EC DECLARATION OF CONFORMITY



pursuant to EU Machinery Directive 2006/42/EC



APV Technische Produkte GmbH
Dallein 15
3753 Hötzelsdorf, Austria

hereby declares that the implement described below complies with the relevant essential health and safety requirements of the directives cited above by virtue of its design and construction and in the configuration we have placed on the market.

If the implement is modified without prior consultation with **APV Technische Produkte** this declaration shall lose its validity.

Designation of the implement:
GRASSLAND PRO HARROW GP 600 M2

Year of manufacture: from **2022**

Serial numbers from 06028-01000

Relevant EC directives:
Directive on machinery – Machinery Directive 2006/42/EC

In the planning, design, construction, and placement on the market of the "Grassland Pro Harrow GP 600 M2" in addition to the directives, the following harmonized European norms have also been applied, in particular:

EN ISO 12100:2010 Safety of machinery – General principles for design – Risk assessment and risk reduction

EN ISO 13857:2020 – Safety distances to prevent hazard zones being reached by upper and lower limbs

EN ISO 13849-1:2015 – Safety of machinery – Safety-related parts of control systems

Responsible for the technical documentation: Planning and Design department, Dallein 15

Ing. Jürgen Schöls
Managing Director
(Authorized person in the EU)

Dallein/Hötzelsdorf, 2022-11-10

2 UK CONFORMITY ASSESSED

pursuant to EU Machinery Directive 2006/42/EC



APV Technische Produkte GmbH
Dallein 15
3753 Hötzelsdorf, Austria

hereby declares that the implement described below complies with the relevant essential health and safety requirements of the directives cited above by virtue of its design and construction and in the configuration we have placed on the market.

If the implement is modified without prior consultation with **APV Technische Produkte** this declaration shall lose its validity.

Designation of the implement:
GRASSLAND PRO HARROW GP 600 M2

Year of manufacture: from **2022**

Serial numbers from 06028-01000

Relevant EC directives:
Directive on machinery – Machinery Directive 2006/42/EC

In the planning, design, construction, and placement on the market of the "Grassland Pro Harrow GP 600 M2" in addition to the directives, the following harmonized European norms have also been applied, in particular:

EN ISO 12100:2010 Safety of machinery – General principles for design – Risk assessment and risk reduction

EN ISO 13857:2020 – Safety distances to prevent hazard zones being reached by upper and lower limbs

EN ISO 13849-1:2015 – Safety of machinery – Safety-related parts of control systems

Responsible for the technical documentation: Planning and Design department, Dallein 15

A handwritten signature in black ink, appearing to read 'Jürgen Schöls', written in a cursive style.

Ing. Jürgen Schöls
Managing Director
(Authorized person in the EU)

Dallein/Hötzelsdorf, 2022-11-10

3 IDENTIFICATION OF THE DEVICE

The Grassland Pro Harrow can be uniquely identified through the following information on the type plate:

- Designation
- Model
- Vehicle class
- Vehicle ID no.

Position of the type plate

The type plate is located on the right of the center frame (see Figure 1).

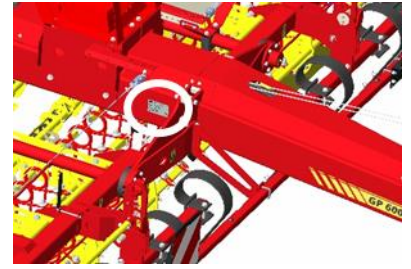

Figure 1

The illustration below (Figure 2) shows the structure of the type plate.

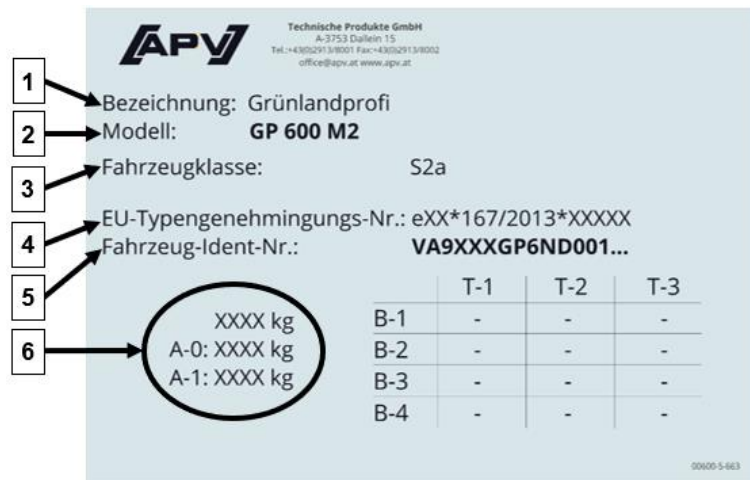

Figure 2

The information on the type plate has the following meaning:

- 1: Designation
- 2: Model
- 3: Vehicle class
- 4: EU type approval no.
- 5: Vehicle ID no.
- 6: Axle load and drawbar load



NOTE!

Always specify your implement's production number/serial number for inquiries or warranty claims.

4 SERVICE

Contact us at our Service address in the following cases:

- If, despite of the information in this operating manual, you have questions concerning the handling of this device
- For questions regarding spare parts
- To commission service and maintenance tasks

Service address:

APV Technische Produkte GmbH
 Zentrale: Dallein 15
 3753 Hötelsdorf
 AUSTRIA

Telephone: +43 2913 8001-5500
 Fax: +43 2913 8002
 E-mail: service@apv.at
 Web: www.apv.at

5 WARRANTY

When taking delivery of the device, check it immediately for any transport damage. Subsequent complaints arising from transport damage can no longer be acknowledged.

Based on a warranty activation (see point 5.1), we provide a six-month factory warranty, starting from the date of first use (your invoice is the warranty certificate).

This guarantee shall apply in the event of material or design errors and does not extend to parts that become damaged through normal or excessive wear.

The warranty shall become null and void under the following circumstances,

- If damage occurs due to external force.
- In the event of an operating error.
- If the kW/HP limit is significantly exceeded.
- If the implement is altered, extended or fitted with third-party spare parts without our authorization.

5.1 WARRANTY ACTIVATION

Every APV implement must be registered immediately after delivery. The registration activates the claim for warranty performances and thus APV can guarantee the best service.

To activate the warranty for your implement, simply scan the QR code with your smartphone – this will take you directly to the Service area of our website.



Of course, you can also activate the warranty through our website www.apv.at in the Service area.

6 SAFETY INSTRUCTIONS

This chapter contains general rules of behavior for proper use of the implement and safety instructions that you must strictly comply with for your own safety.

The list is quite extensive, and some information does not just pertain to the provided implement. However, the summary of the information will often remind you of safety rules that are unconsciously disregarded when using the machines and implements in day-to-day work.

6.1 INTENDED USE

The implement has been built exclusively for customary use in agricultural tasks (intended use).

Any use that beyond this is non-intended use. The manufacturer shall not be liable for damage that is incurred through non-intended use; the user alone bears the associated risk.

Intended use also includes compliance with the operation, service and maintenance conditions that are prescribed by the manufacturer.

The implement must only be used, maintained, and repaired by people who are familiar with with the implement and have been instructed with regard to the hazards. Ensure that all safety instructions are passed on to other users as well.

The relevant, country-specific accident prevention regulations and other generally recognized safety, occupational health and safety, and road traffic regulations must be complied with.

Unauthorized changes to the implement exclude any and all liability on the part of the manufacturer for the resulting damage. This causes the Declaration of Conformity to lose its validity.

6.2 GENERAL SAFETY INFORMATION AND ACCIDENT PREVENTION REGULATIONS

- The warning and information signs affixed on the implement provide important instructions for safe operation. Do not remove the warning and information signs under any circumstances. Comply with the warning and information signs for your own safety!
- There are crushing and shearing points on power-operated parts (e.g. hydraulically-operated parts)!
- Intended use excludes the carrying of people on the implement, whether on agricultural areas or roads.
- Release parts for fast couplers must be freely suspended, and they must not release on their own in the low position!
- Comply with the generally valid safety regulations and accident prevention regulations of the respective country!
- Transport of the implement on public roads requires compliance with the respective national licensing regulations and road traffic regulations.
- When implement parts are moving (e.g. during the folding or pre-loading procedure) ensure that no one is standing in the danger zone of the implement – there is a risk of crushing.
- When using the platform kit, ensure that the implement has come to a standstill, that it is also unfolded, and that it is lowered onto the ground.
- When mounting the implement on the towing vehicle, the owner must particularly ensure compliance with tractor requirements regarding power, total weight, transport dimensions, axle loads, and weight distribution as stipulated in the operating manual; the owner must also ensure that the connections are properly established as specified in the operating manual.
- When driving under low obstructions or through narrow obstructions (e.g. power lines, underpasses, etc.) pay attention to the height and width of the implement to avoid collisions.
- When driving on public roads, which is only permitted with extended chassis (both wheels), folded side wings, and pulled-in rollers (hydraulic cylinders of the roller adjustment completely retracted) the control block on the chassis cylinder prevents lowering of the Grassland Pro Harrow as well as lowering of the folded components (additionally secured with catch hooks) even if the tractor hydraulic system fails.
- Take into account the wide load and/or the implement's oscillating mass when turning! Take the wide sweep into account!
- If necessary, use additional lighting (e.g. hand lamp) for repair or maintenance tasks.
- For high-speed implements with ground-driven tools: Danger after lift-out due to continued movement of the centrifugal mass! Only approach implement after it has come to a complete standstill!
- If implement parts are lost or broken, they must be immediately replaced with original parts by trained specialist personnel.
- Bring the support devices into their respective positions when mounting and dismounting the implement (stability)!
- Special caution is required when coupling implements onto or uncoupling implements from the tractor!
- Do not use the implement if you are tired or under the influence of drugs, alcohol or medications.
- Climbing onto the implement or walking on the implement is only allowed if a platform kit is installed and if the implement is at standstill.
- The implement may only be used on agricultural land. It must not be used on normal road surfaces, on asphalt or concrete. In particular, the implement must not be used for building industry applications on construction sites, for winter service, for road construction, or for underground mining.
- This implement must only be used by expert personnel who are informed of the danger zones and who are familiar with the regulations for transport on public roads. The owner is responsible for regularly monitoring user suitability
- The implement is intended for outdoor operation in dry weather, within a temperature range from +5 °C to 40 °C. Water ingress must be prevented. The implement must not be used in rain or storm conditions; it must be parked under a roofed shelter.
- Carrying passengers while working and transporting them on the implement are prohibited!

- Do not transport work materials on the implement; the exception is seed in the hopper of a Pneumatic Seeder that may be attached.
- Accessories must be properly mounted in compliance with standards by qualified specialists from an appropriately authorized company.
- Do not position yourself in the work area!
- The operator/user must ensure that no one is standing in the vicinity of the implement, when it or its components are moved via the tractor hydraulic system, or when the roller is lifted or lowered. The driver must perform a visual inspection!
- With first use of the implement, the operator/user confirms that they have read and fully understood this operating manual.
- When mounting the Grassland Pro Harrow the owner/user must connect the Grassland Pro Harrow to the tractor by means of a mechanical connection (ensured by the lower link).
- The owner must train and instruct their personnel prior to first use of the implement. Personnel/users must have read and understood this operating manual before they handle the implement.
- The owner/user must carefully and cleanly establish the connections to the tractor hydraulic system when assembling the implement.
- The operator/user should wear tight-fitting clothing! Avoid loose or baggy clothing!
- The instructions concerning assembly as well as the requirements imposed on the tractor as specified in the operating manual must be complied with.
- Do not exceed 12 km/h forward speed when performing field passes.
- The operator/user must regularly check the implements (before each use) for breakage, cracks, abrasion points, leaks, loose bolts or loose threaded connections, vibration, abnormal noises, and proper function.
- A clear view of the attached implement and the hazardous movement area is required to monitor the procedure.
- Secure the folded-in frame and lift-out units in transport position!
- Ensure that the hydraulic couplings are not soiled.
- Always wear protective goggles, hearing protection, and tight-fitting protective work gloves when performing coupling tasks (compressed air connections, hydraulic connections, etc.).
- Handling, steering, and braking capability are also affected by mounted or attached implements and ballast weights. Consequently, ensure that there is adequate steering and braking capability!
- When passing on the implement, always pass on the operating manual.
- Always ensure that the implement is secured against unintentionally rolling when parking.
- Only operate the device when all protective devices are installed and in the protective position!
- Properly hitch the implement and fasten only to the prescribed fixtures!
- Always install the weights properly at their designated fastening points!
- Keep the operating manual in the vicinity of the implement at all times for reference purposes.
- Hydraulic folding frames must only be activated if no one is in the swivel range.
- Always perform repair, maintenance and cleaning tasks, and always eliminate malfunctions only after the drive is powered off and the engine has come to a standstill, and only after verifying de-energized status!
- Inspections must be performed before operation or as part of regular care and maintenance of the implement.
- Do not position yourself in the implements turning and swivel range!
- Always keep hands, clothing etc., away from rotating parts!
- Check and install transport equipment, such as lighting, warning devices, and any protective devices!
- Do not work under the implement – particularly when it is lifted, unless an appropriate support device is properly installed beneath the implement.
- Before beginning work, familiarize yourself with all the devices, activating elements, and their functions. It is too late to do so during work implementation!
- Always perform a visual inspection of the mechanical folding lock before start-up.
- Check your immediate surroundings (watch out for children) before start-up! Ensure that you have an adequate view!

- Before exiting the tractor, activate the brake on the implement, prevent unintentional rolling, switch off the engine, and remove the ignition key!
- Before each use, check the folding device and its securing elements for proper function and effect.
- Each time before start-up, check the implement and the tractor for road safety and operational safety (e.g. defective parts, connections, hoses, guards, etc.)!
- Never leave the driver's platform while while implement and tractor are in motion!
- Comply with the permissible axle load, total weight, and transport dimensions!
- Keep the implements clean to prevent a fire hazard!
- Do not allow anyone to enter the area between the tractor and implement without first preventing the vehicle from rolling via the parking brake and/or the wheel chocks!

6.3 ATTACHED IMPLEMENTS

- Only APV machines and accessories may be mounted on the implement.
- Do not step between the tractor and implement when activating the external control operating unit for the three-point attachment!
- When driving on roads, which is only permitted with the implement lifted and with folded side frames, a load-safety valve on the chassis cylinder prevents lowering of the implement and lowering of the folded side frames by means of a mechanical folding lock. Moreover, the roller frame and the tines must be completely set down (roller frame hydraulically and tines mechanically).
- The mechanical folding lock prevents unintentional lowering of the side frame during road transport in the event that the tractor hydraulic system fails.
- For road travel with lifted implement, the operating lever must be locked to prevent lowering!
- For three-point mounting, the attachment categories for the tractor and implement must match or be agreed!
- Mounting of any accessories on the implement must be executed in accordance with standards. The maximum permitted configured weight / total weight of the implement must not be exceeded.
- There is a risk of injury due to crush and shear points in the three-point linkage area!
- Always ensure that the tractor three-point linkage is adequately arrested on the side when the implement is in transport position! If necessary, brace the lower link to prevent oscillation of the implement.
- Before mounting and dismounting implements on the three-point linkage, bring the operating devices into the proper position that prevents unintentional lifting or lowering!

6.4 HYDRAULIC SYSTEM

- Due to the danger of injury, use the appropriate aids when looking for leaks!
- For hydraulic function connections between tractor and implement, coupling sleeves and coupling connectors must be marked so that the possibility of operating error can be excluded! Mixing up the connections reverses the function (e.g. lifting/lowering)! – Danger of accident!
- Ensure that the hydraulic hoses are connected as prescribed when connecting hydraulic cylinders and hydraulic motors!
- When connecting the hydraulic hoses to the tractor hydraulic system, ensure that the hydraulics on both tractor and implement are depressurized!
- The hydraulic system is under high pressure when the implement is in operation! Do not disconnect hydraulic hoses until after the hydraulic system on the towing vehicle and the implement are depressurized.
- Regularly inspect hydraulic hose lines and replace them if they are damaged or ageing! The replacement hoses must meet the technical requirements specified by the implement manufacturer!
- Liquids that escape under high pressure (hydraulic oil) can penetrate the skin and cause severe or fatal injuries! If there are injuries, seek medical attention immediately! (Danger of infection, blood poisoning!)
- Before performing tasks on the hydraulic system, place the implement on the ground, depressurize the system, and switch off the engine!

6.5 MAINTENANCE

- Disconnect the cables on the generator and battery when performing electrical welding tasks on the tractor and attached implements!
- If necessary, use additional lighting (e.g. hand lamp) for repair or maintenance tasks.
- If damaged, it must be replaced immediately before working with the implement!
- When performing maintenance tasks on the raised implement, always prevent it from lowering by means of appropriate support elements!
- Use suitable tools, protective goggles and cut-resistant gloves when replacing work tools with sharp edges!
- Components that cannot be removed with tools, such as a screwdriver or wrench, may only be replaced by qualified specialists from an appropriately authorised company or by APV Customer Service.
- The operator/user must check the implement (each time before use) for any fractures and cracks, leaks, abrasion points, loose bolts or connections, vibration, and correct function.
- The implements must be regularly lubricated and cleaned with water or compressed air. While doing this, personal protective equipment must be worn if necessary.
- Cleaning, maintenance, and repair tasks must be carried out with the implement lowered, engine switched off, and safeguarded to prevent it from being switched on again.
- The maintenance tasks themselves must only be performed by trained specialists and must never be performed alone. The utmost caution is required when replacing defective components or tools.
- Spare parts must at least meet the technical requirements specified by the implement manufacturer! Original parts meet these requirements!
- We recommend a gentle cleaning as specified in the maintenance instructions. In this regard you must proceed as specified in the maintenance manual and protective equipment must be used.
- Always perform repair, maintenance, and cleaning tasks, and eliminate malfunctions when the drive is switched off, the engine is at a standstill, and the implement has been uncoupled from the towing vehicle! Remove the ignition key! Check to ensure de-energized status!
- Regularly check nuts and bolts for firm seat and retighten if necessary!
- Properly dispose of oil, grease, and filters in accordance with local regulations!
- If repair or maintenance tasks are required on the implement, a clearly visible information sign "Caution: Maintenance Tasks" must be provided to alert others.
- Do not work under the implement!
- Always disconnect the power supply before working on the electrical system!
- During possible continued motion due to centrifugal mass maintain a safe distance from the implement. Work can only be performed after it comes to a complete standstill!

6.6 TIRES

- For tasks on tires, ensure that the implement has been safely parked and secured against rolling off (wheel chocks).
- Installing wheels and tires requires adequate knowledge and the prescribed installation tools!
- Regularly check the tire pressure!
- Regularly check wheel nuts for firm seat, required torque, and retighten if necessary.
- Repair tasks on the tires must only be performed by specialists and with the appropriate assembly tool!

6.6.1 LOAD INDEX AND SPEED INDEX

Tire dimensions	Load index		Speed index	
	Index	Load capacity	Index	Speed
500-50-17	140	2500 kg	A8	40 km/h
400-60-15.5	145	3150 kg	A8	40 km/h
12.5-80-18	142	2650 kg	A8	40 km/h

6.7 ATTACHED SEEDERS

- When using a seeder, all the instructions provided by the implement manufacturer must be complied with.
- The seeder can be reached easily via a step and a platform. The ladder and platform must be clean and dry for use.
- The platform kit must only be used as a maintenance walkway.
- A ladder must be made that is in conformance with standards. This ladder is available from APV.
- When not in use, the steps must be swung upward and secured.
- Standing on the platform or the steps is strictly prohibited when the implement is in motion.

6.7.1 FILLING THE SEEDER

- When filling the seeder, never stand under a suspended load!
- When driving up to the implement with seed, ensure that no one is standing on or around the implement.
- Only fill the seeder by means of a filling auger or a supply vehicle.
- The platform kit must not be used to fill the seeder or used as a storage area for objects or seed.
- During the loading procedure, avoid any contact with the treated seed; wear gloves, a dust mask, and safety goggles.

CAUTION!

Printing errors excepted, all information without guarantee.

6.8 DANGER AREAS

CAUTION!

Danger area when the implement is in motion

The danger area of the implement moves along with the implement in operation. The danger area includes the area across the entire width of the implement in the direction of travel (see Figure 3). An additional safety distance of 2 m from the implement must be maintained on each side.

- While driving on the field, keep an eye on the entire danger area. Come to a stop if necessary.
- Never climb down from the tractor while it is in motion.
- Never let other people climb on or off while the implement is in motion.

CAUTION!

Risk of impact and crushing due to moving implement parts

Moving implement parts pose a risk of injuries due to impact or crushing. The danger area includes the area across the entire width of the implement (see Figure 3). Maintain an additional safety distance of 2 m from the implement.

Ensure adequate clearance above the implement. The required clearance depends on the width of the moving implement parts and the lifting height.

- Check the danger area before folding and unfolding.
- Keep an eye on the danger area during the folding procedure. Interrupt the folding procedure if necessary.

6.8.1 DANGER AREAS IN IMPLEMENT OPERATION

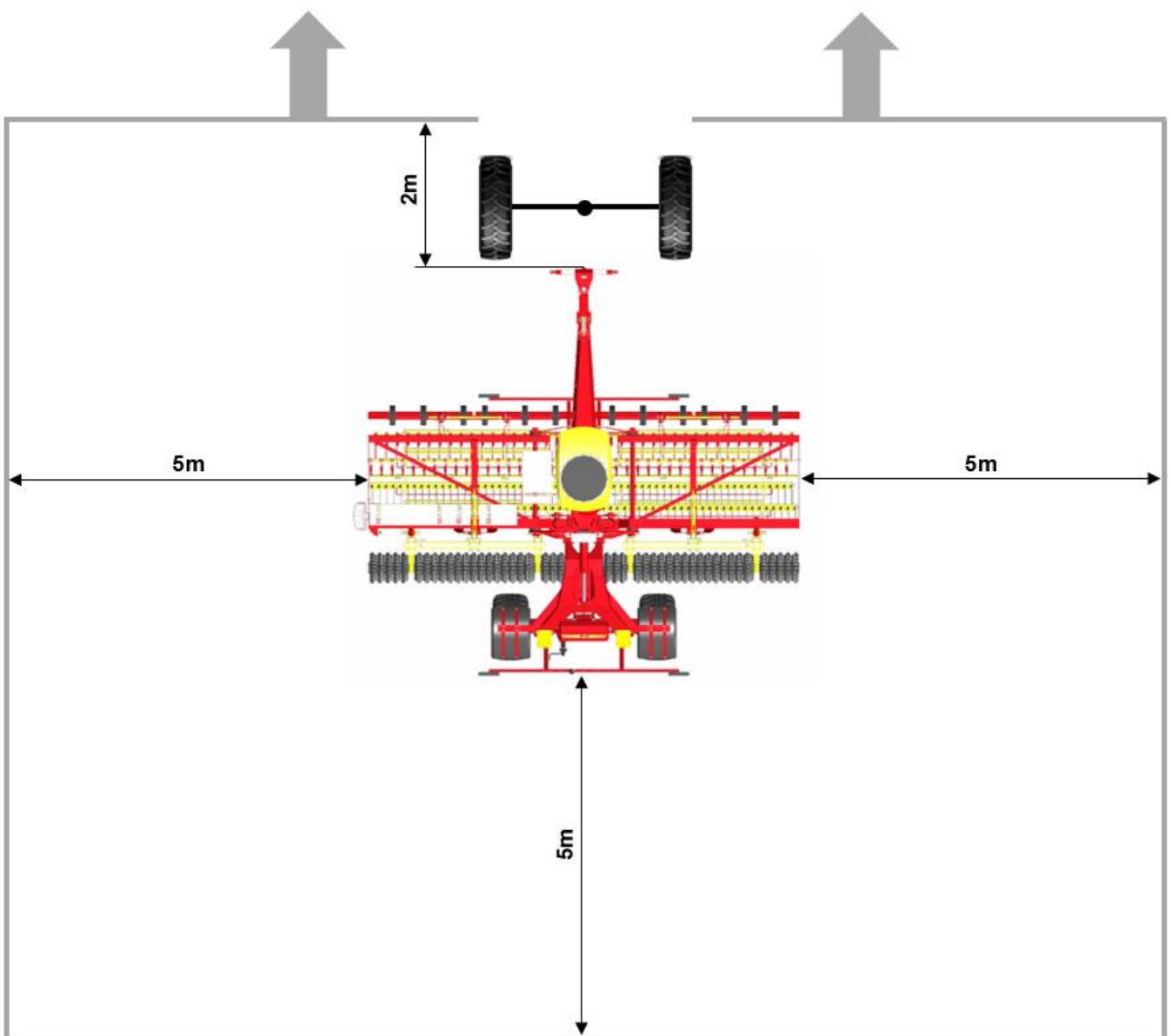

Figure 3

6.8.2 DANGER AREAS WHEN FOLDING AND UNFOLDING

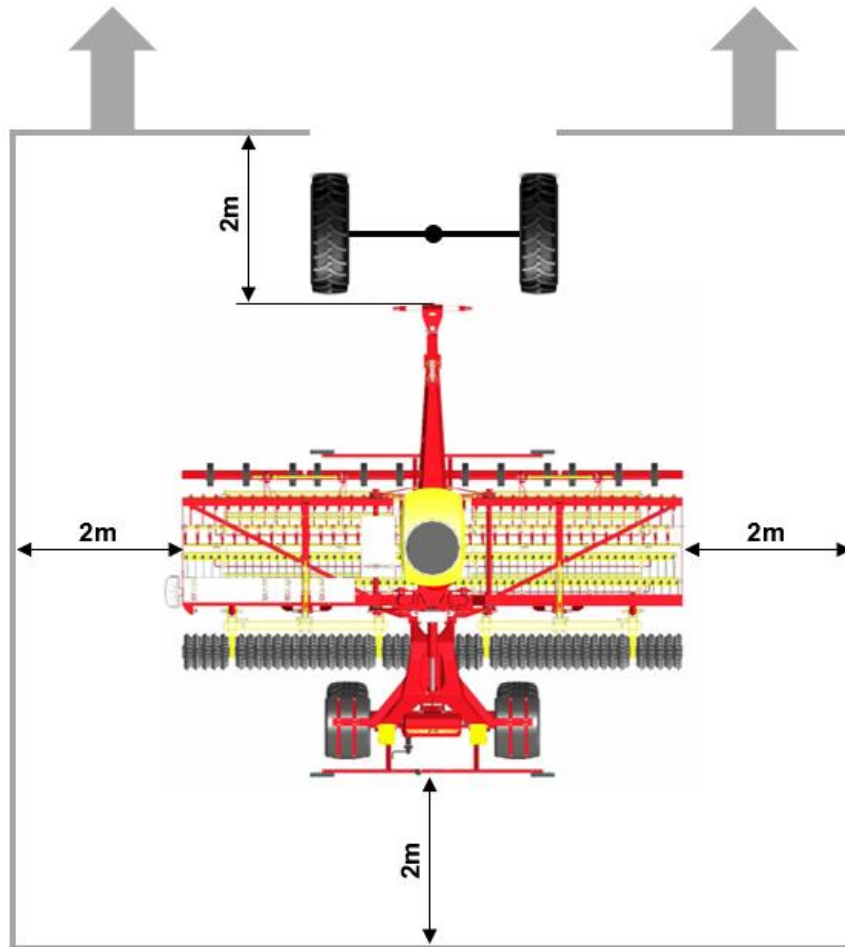

Figure 4

6.9 RESIDUAL HAZARDS

Residual hazards are special hazards when working with the implement that cannot be eliminated despite safety-compliant design.

Residual hazards are often not obvious and can be a source of possible injuries or health risks.

6.9.1 DANGER ARISING FROM MECHANICAL SYSTEMS

There is a risk of accidents due to crushing, cutting, and impact on body parts

- on implement parts that move unexpectedly,
- on implement parts that move due to stored mechanical energy,
- on elastic parts such as springs,
- due to insufficient stability of the implement,
- due to the general shape or attachment location of components.

6.9.2 DANGER ARISING FROM HYDRAULIC SYSTEMS

There is a risk of injury to body parts, particularly face, eyes, and unprotected skin areas, due to burning and contamination with hydraulic oil

- due to hot/pressurized hydraulic oil spraying out from leaky connection points or lines,
- due to bursting of pressurized lines or components,
- due to skin contact.
- Wear personal protective equipment!

6.9.3 DANGERS ARISING FROM OPERATION

In operation, there is a risk of injury to body parts, particularly the face, due to rocks and clods of soil being flung upwards.

7 INFORMATION SIGNS / HAZARD LABELS



Pay attention to the stickers on the implement; they warn of particular hazards!







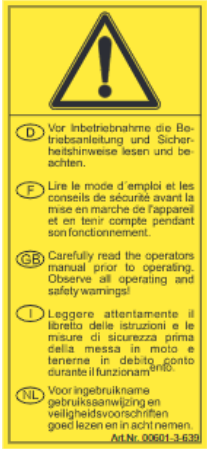

CAUTION!

Keep information signs and hazard labels clean

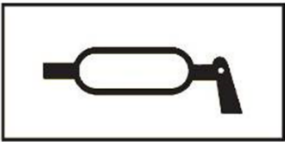

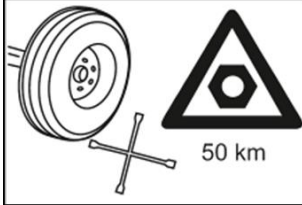
If information signs and/or hazard labels become loose or are already detached, they must be replaced without delay. The respective order numbers are provided in sections 7.1 and 7.2. Contact our service organization in this regard, see section 4 Service.

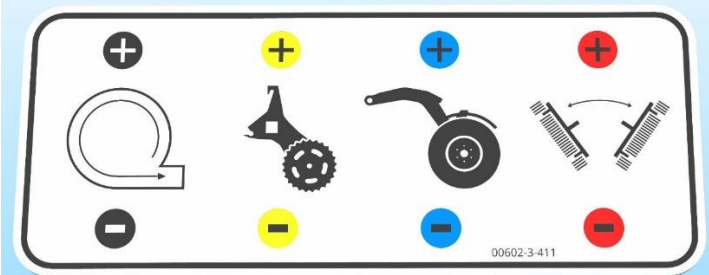

7.1 INFORMATION SIGNS

<p>Information sign</p>			
<p>Order number</p>	<p>00603-3-665</p>	<p>00602-3-293</p>	<p>00601-3-639</p>
<p>Explanation</p>	<p>Read and comply with the operating manual before start-up!</p>	<p>Do not stand on the implement while it is moving!</p>	<p>Read and comply with the operating manual and safety instructions before start-up.</p>

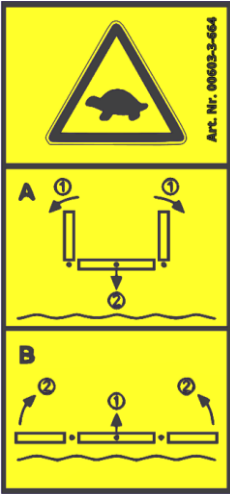
<p>Information sign</p>		 <p>(symbolic representation)</p>	
<p>Order number</p>	<p>00603-3-687</p>	<p>00600-3-138</p>	<p>00600-3-163</p>
<p>Explanation</p>	<p>Retighten all bolts and nuts after brief use.</p>	<p>These stickers indicate the tire pressure.</p>	<p>Labelling of the lubrication points.</p>
<p>Information sign</p>			
<p>Order number</p>	<p>00602-3-119</p>	<p>00600-3-139</p>	<p>00601-3-658</p>
<p>Explanation</p>	<p>Label for the recess for mounting the 24-mm pins.</p>	<p>Retighten the wheel nuts / wheel bolts after 50 hours or 50 km.</p>	<p>Loading hook. Fasten the cable or chains here when loading the implement!</p>
<p>Information sign</p>			
<p>Order number</p>	<p>00602-3-411</p>		<p>00602-3-524</p>
<p>Explanation</p>	<p>Connections for the hydraulic system</p>		<p>Receptacle point for the lifting jack. To lift the implement, place the jack at this point.</p>

7.2 HAZARD LABELS

<p>Information sign</p>			
<p>Order number</p>	<p>00604-3-648</p>	<p>00603-3-664</p>	<p>00602-3-294</p>
<p>Explanation</p>	<p>Caution, crushing area! Never reach into the crush hazard zone as long as parts are moving in this zone!</p>	<p>Always lift the implement slowly off the ground.</p>	<p>Attention – do not climb onto the implement! Rollover hazard!</p>

<p>Information sign</p>		
<p>Order number</p>	<p>00602-3-764</p>	<p>00602-3-763</p>
<p>Explanation</p>	<p>Danger due to ejected parts; maintain a safety distance of 5 m!</p>	<p>Danger due to ejected parts; maintain a safety distance of 2 m!</p>

7.3 PLACEMENT OF THE HAZARD LABELS AND OTHER MARKINGS

The figures below show the arrangement of the hazard labels and other markings.

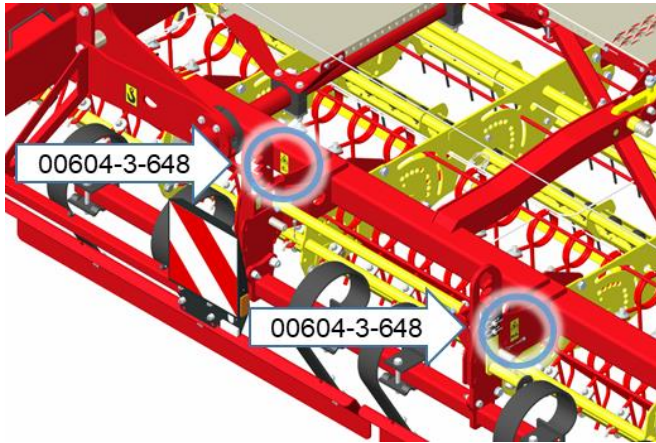

Figure 5

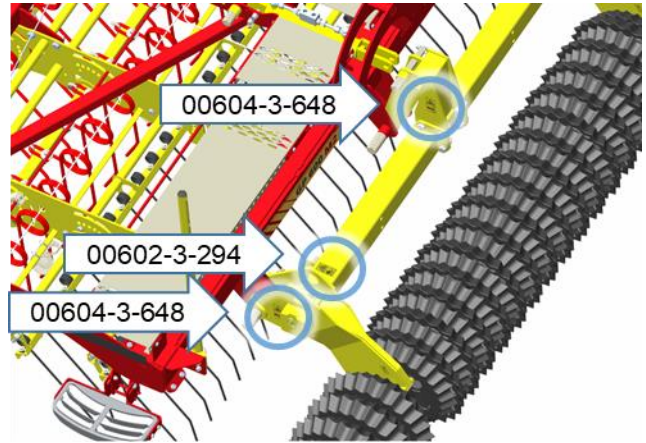

Figure 6

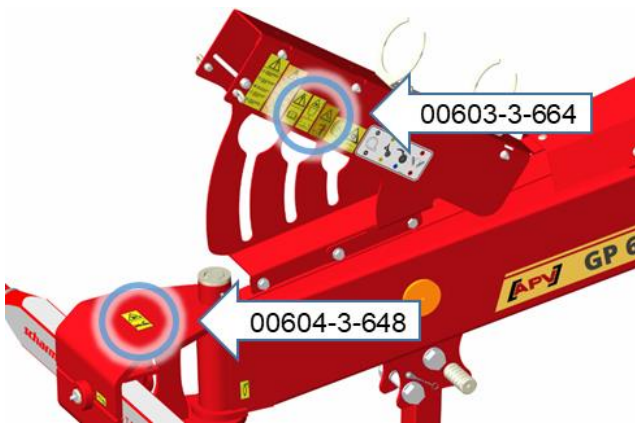

Figure 7



Figure 8

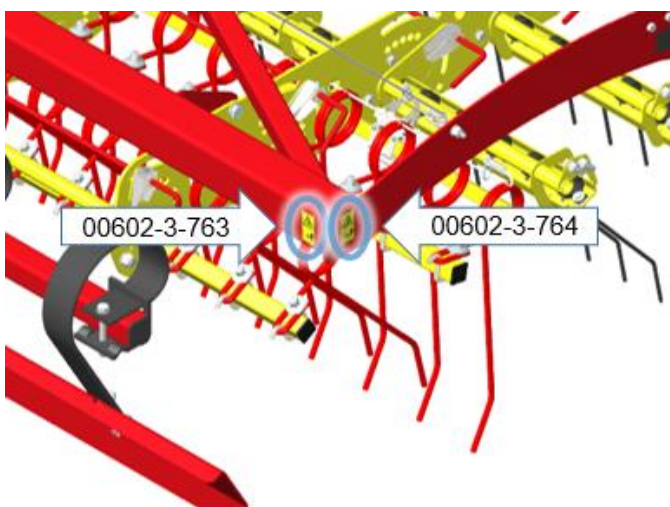

Figure 9

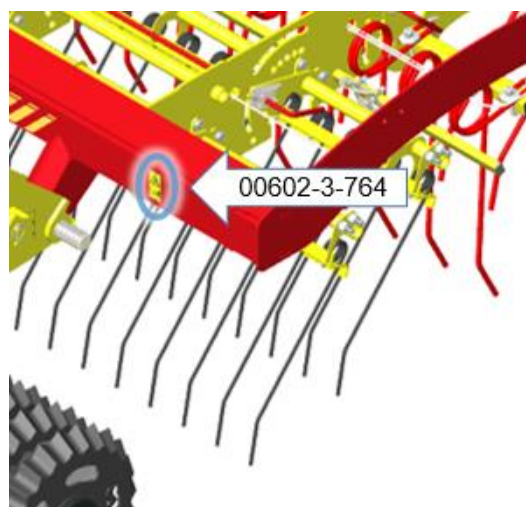

Figure 10

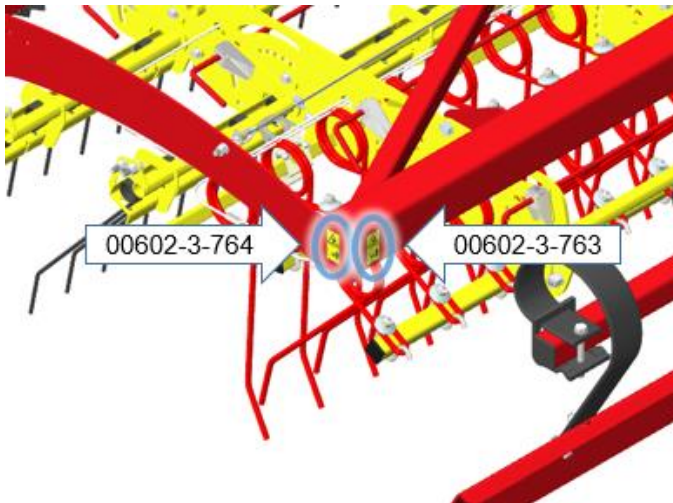

Figure 11

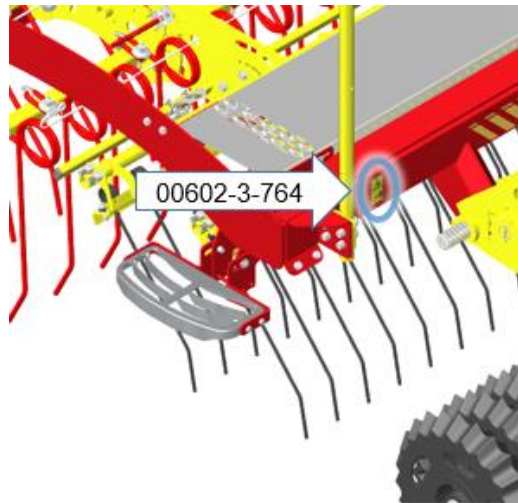

Figure 12

8 OPERATING MANUAL

8.1 STRUCTURE AND MODE OF OPERATION

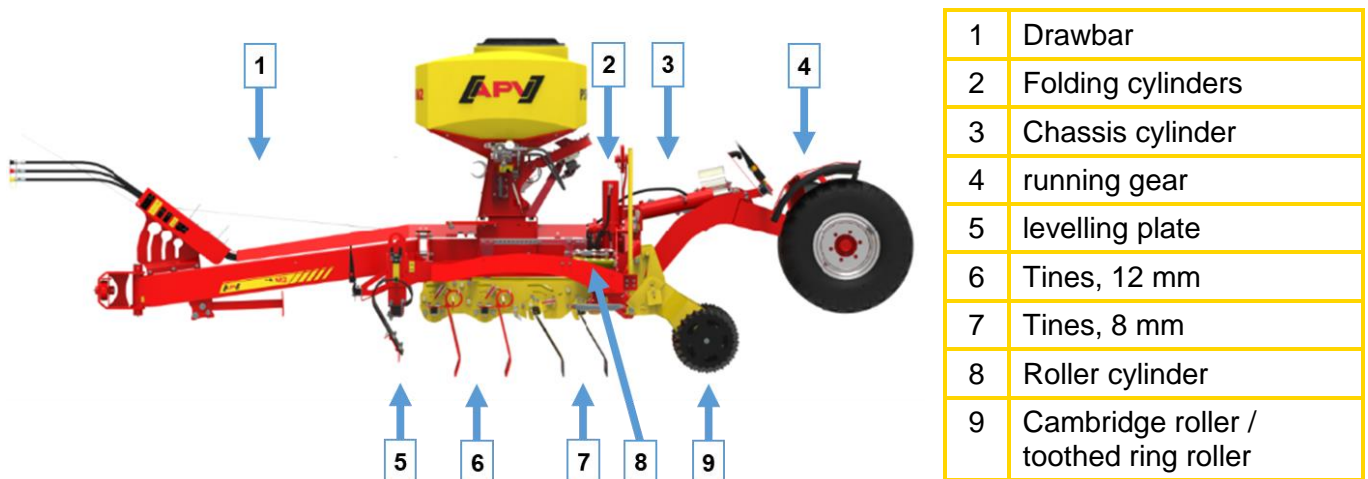

Figure 13

Thanks to its robust and compact design, the Grassland Pro harrow is ideal for new seeding, reseeding, and controlling weeds on grassland.

The spring-suspended levelling board ensures optimal distribution and levelling of molehills, manure, slurry, and cow pats.

Due to the narrow line distances of the individual tines, the sward is optimally prepared and the reseeding can germinate rapidly.

With the high contact pressure of the roller that is used, soil contact of the seed is improved and nutrient supply for the reseeding is optimized.

To obtain the best possible rolling results, do not exceed a forward speed of 8 km/h. A speed of 6-12 km/h is ideal for grassland.

8.2 ATTACHMENT AND DETACHMENT OF THE IMPLEMENT

8.2.1 GENERAL INSTRUCTIONS

- The tractor tire pressure must be selected as specified by the tractor manufacturer.
- Additional wheel weights can be advantageous for difficult operating conditions. Comply with the information provided by the tractor manufacturer.
- To ensure steering and braking capability, the tractor must be adequately equipped with ballast weight on the front. At least 20% of the unladen vehicle weight is required on the front axle.
- The lifting struts must be adjusted to the same height, left and right, and locked.
- The implement must be mounted on the factory-standard lower link.
- Comply with the stickers on the implement and the information provided by the tractor manufacturer.
- Special caution is required when backing up the tractor. Do not stand between the tractor and the implement.

8.2.2 PARKING BRAKE

Use the parking brake to prevent the implement from rolling. In particular, ensure that the parking brake is engaged when uncoupling the implement.

To engage the parking brake, turn the crank (see Figure 14) clockwise – to release the parking brake, turn the crank counterclockwise.

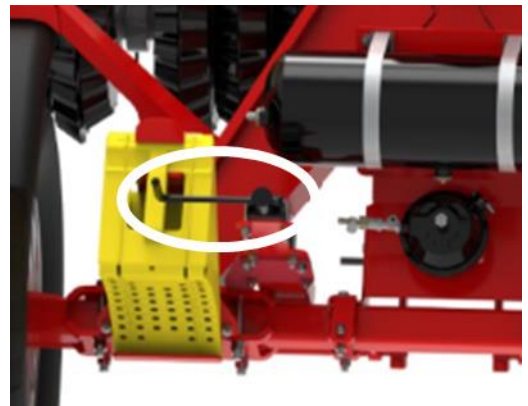

Figure 14: Symbol image

8.2.3 COUPLING

- The tractor lower links must be locked to prevent lateral oscillation so that they do not start swaying while the tractor is in motion.
- The implement is connected on the lower links of the tractor; the lower links of the tractor are standardized in accordance with CAT 3N. This means that the balls have a lateral distance of 825 mm. The width of the balls is 45 mm.
- The pneumatic brake system (if present) must be connected.
If a pneumatic brake system is present, the preloaded tractor must be equipped with a pneumatic brake system, which must be coupled for operation. If not, undefined states of the pneumatic brake system can occur that can severely damage the chassis axle.

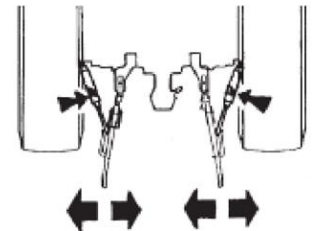

Figure 15

CAUTION!

Comply with the sequence for connecting the pneumatic brake system! First couple the yellow brake line, then couple the red brake line.

- The wheel chocks must be removed and hooked into the holder provided for this purpose.
- The parking brake is released.
- The hydraulic hoses must be connected to the 3 double-acting control units.

CAUTION!

Only connect the hydraulic hoses when the hydraulic system on the towing vehicle and the implement are depressurized.

- The lighting and electrical cables (if present) must be connected.
- The lighting function must be tested.



Figure 16

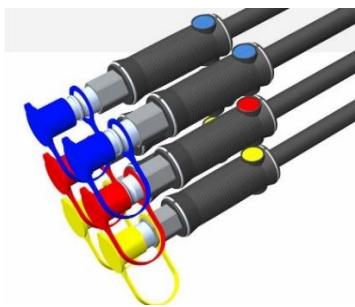

Figure 17

1	Hydraulic connections for roller (yellow dust caps)
2	Hydraulic connections for chassis (blue dust caps)
3	Hydraulic connections for Pneumatic Seeder and pressureless return (if present)
4	Implement cables for Pneumatic Seeder (if present)
5	Hydraulic connections for folding (red dust caps)
6	Connections for pneumatic brake (if present)
7	Connection for lighting (if present)

- Check that the hoses and cables hang freely so that they are not damaged in tight curves.
- The parking support must be swung upward and secured. To do this pull out the pin (Figure 18), swing the parking support upward and fix it in place with the pin (Figure 19).



Figure 18



Figure 19

8.2.4 UNCOUPLING

In coupled status, the implement must be uncoupled or parked on a stable and horizontal substrate so that the support does not sink into the ground and so that the implement cannot roll. To uncouple the implement proceed in the reverse of the coupling sequence described in Point 8.2.2.

CAUTION!

Always secure the implement to prevent it from rolling.

CAUTION!

Prior to uncoupling, you must check again to ensure that the mechanical folding lock is locked in place.

CAUTION!

Comply with the sequence for locking the pneumatic brake system ! First uncouple the red brake line, then uncouple the yellow brake line. This is precisely the reverse of the sequence described for coupling the implement.

Ensure that the chassis cylinders and the parking support are adjusted such that the implement rests on the wheels, the rollers, and on the parking support (see Figure 20).



NOTE!

Place a block of wood 10 to 12 cm in height under the roller shaft. This ensures that the tine beds do not rest on the ground.

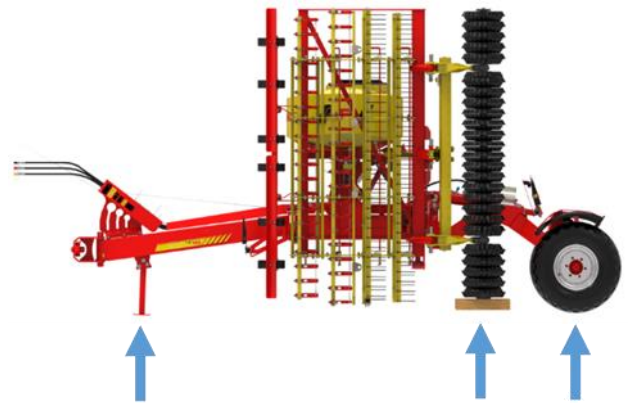

Figure 20

After disconnecting the hydraulic hoses, place the cabling and pressure hoses in the holding fixture (see Figure 21).



Figure 21

8.3 UNFOLDING FROM TRANSPORT POSITION TO WORK POSITION

The hydraulic cylinders for depth adjustment of the rollers must be in the maximum possible retracted position. Only unfold the implement under these conditions, otherwise massive collisions or warping can occur between the two roller segments.

The amount of oil on the control units of the coupled tractor must be appropriately reduced, so that the entire fold procedure runs slowly (at least 12 seconds) and in a manner that is gentle on the machine.

After completely unfolding, the control unit on the coupled tractor must be placed in float position, to ensure the desired ground adaptation of the implement.

If the implement is unfolded or operated counter to these instructions, any liability on the part of the manufacturer is excluded.

8.4 FOLDING FROM WORK POSITION INTO TRANSPORT POSITION

The hydraulic cylinders for depth adjustment of the rollers must be in the maximum possible retracted position. When using the 410 mm toothed ring roller the total length of the clips that are used on the roller cylinders must not exceed 100 mm. If the total length of the clips that are used exceeds 100 mm, the clips must be dismantled before road transport to maintain the road transport width of < 3.0 m. When using a roller with a greater diameter, the mounted clip length must be correspondingly reduced to maintain the road transport width of < 3.0 m. The control unit on the coupled tractor for adjustment of the roller hydraulic cylinders must be appropriately secured during road travel, so that the road transport width cannot be inadvertently misadjusted, i.e. increased.

8.5 WORKING POSITION AND ADJUSTING THE WORKING DEPTH

8.5.1 DEPTH ADJUSTMENT / DRAWBAR ADJUSTMENT

The working depth of the implement is adjusted via the roller setting and the height of the lower links:

1. Take off or fit on the hydroclips, depending on how aggressively the soil should be worked. Only adjust the working depth via the roller cylinders in lifted and folded transport position because the clip carriers on the implement cannot be reached without danger. After the newly selected number of clips have been mounted on the roller cylinders, the machine must again be brought into unfolded work position and the newly selected working depth must be tested. This procedure must be repeated until the right working depth has been determined.



Figure 22

Careful attention, is required when dismantling the clips so that the aluminum shells do not fall out of the spring clamps, because they cannot be separately secured.

To mount the clips, the roller cylinders must be slightly extended. To avoid an over-fast movement of the roller cylinders, the flow rates on the control units of the coupled tractor must be set to minimum oil quantities.

After the desired number and thickness of hydroclips have been hooked in or removed, the roller cylinders must again be retracted to the stop.

CAUTION!

For all cylinders, the same number of hydroclips in the appropriate thickness must be mounted.

2. The lower link must be positioned such that the frame of the implement is parallel to the field. With the position of the lower links, the working depth can also be adapted as required.

TIP!

The working depth must be checked after 10 m travel and re-adjusted if necessary. For larger work areas, the working depth of the tines must be checked from time to time.

8.5.2 ADJUSTING THE SERIES OF HOLES

In addition to depth adjustment, the aggressiveness of each individual tine row can also be changed individually. This makes it possible to compensate for the different levels of wear of the individual tines.

For series of holes adjustment, the pins of the tine sections are inserted either in a higher / more forward or deeper / more rear-ward hole (see Figure 23).

The front two rows of tines (12 mm tines / red) tear open the sward, the rear tine rows (8 mm tines / black) produce an optimal seedbed for the new grasses.

If the front row of tines (12 mm / red) should work the ground more aggressively (e.g. in hard soil conditions), you must place the pin in one of the rear holes. For soft soils or wet conditions, it is possible to only have the rear tines (8 mm tines / black) engage, by moving the front tine rows (12 mm tines / red) upwards (front-most hole).

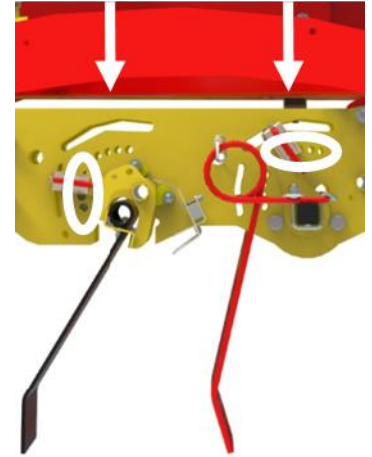

Figure 23

If you want to adjust the work pattern of the rear 8 mm tines (black), select one of the four levels. At optimal forward speed, the tines execute an elliptical movement. The steeper the angle of the tines, the smaller the motion. The shallower the angle of the tines, the larger the motion. If the sward is dense and intense tillage is required, the tines should be positioned more steeply (see Figure 23).

8.6 USING SPECIFIC TOOLS

It is possible to use specific tools of the implement (leveling plate, harrow, and roller) separately or in any combination.

For example, you can use the just the roller alone by completely extending the roller cylinder. In this way, you can also use the implement on field crops for rolling after seeding.

If you only want to level or work the soil with rollers, the roller and the leveling plate are placed downward and the tine rows are rotated upward, so that they are lifted off of the ground.

If you want to only use the implement to harrow, then instead of the rollers, feeler wheels are mounted, the leveling plate is moved upward, and the implement is placed on the feeler wheels.

8.7 LEVELLING PLATE

The levelling plate eliminates molehills after winter and is used for rough leveling of the grassland. The height should be adjusted so that it runs along the sward just above the ground. It should not scrape into the sod. However, if the sod is quite uneven, allowing the levelling board to slightly penetrate into the sod can improve the long-term levelling effect.

To adjust the working height, remove the 2 locking pins, crank the leveling plate to the desired height and fix it in place at the new height with the lock pins (Figure 24).

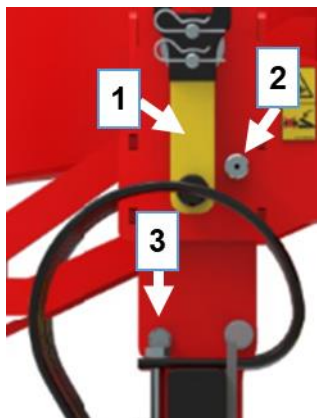

Figure 24



Figure 25

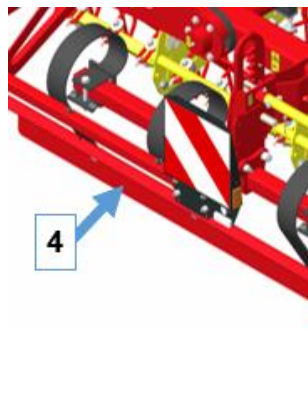

Figure 26

1	Crank
2	Locking pins
3	Shear bolt
4	Levelling plate

CAUTION!

Only operate the crank with one hand; two-hand operation poses a considerable risk of injury (hand or finger injuries). The crank has a slip safeguard for better handling and transmission of force.

Note that crank operation requires high activation forces to adjust the leveling plate. If the user or operator is unsure as to whether the required activation forces can be applied, the levelling rails must be secured with blocks placed underneath them.

TIP!

First remove the right pin, and then remove the left pin so that you can more easily lift the leveling plate.

The levelling plate has a shear guard/ to prevent frame damage due to excessive load on the levelling plate.

NOTE!

The implement accessories include 3 sets of shear bolts. When these have been used, pay attention to the quality of the replacement bolts. Only use M12x60 bolts with a quality of 4.6. Do not exceed the tightening torque of 10 Nm for the M12 bolts. If the M16 bolts behind have loosened, then in this case a maximum tightening torque of 15 Nm must be complied with (Figure 24).

8.8 COUPLING AND UNCOUPLING THE ROLLER

Proceed as follows to couple the roller:

1. The implement is unfolded on a paved and level substrate.
2. The implement is completely lifted out with the chassis cylinder, the lower links are let down as far as possible.
3. The roller cylinder is completely retracted.
4. The parking support of the roller frame is mounted, this is located on the side in the roller frame (see Figure 27).
5. The locking pins of the rollers are removed (Figure 28).
6. The roller cylinder is completely extended.
7. The tine rows are placed in the position shown in Figure 29.
8. The implement is carefully lowered completely and the chassis is pulled fully upwards. Now the implement is supported only by the tine rows.
9. The roller is now uncoupled and can be transported to the rear and away from the implement. If you want to recouple the roller onto the implement, proceed in the reverse sequence.



NOTE!

Note that by removing the rollers, uniform depth guidance may no longer be ensured. For this reason, after dismantling, the rollers must always be replaced by feeler wheels.



CAUTION!

Only mount or dismount the rollers using the mounting kit for feeler wheels (see point 18.9).



Figure 27



Figure 28

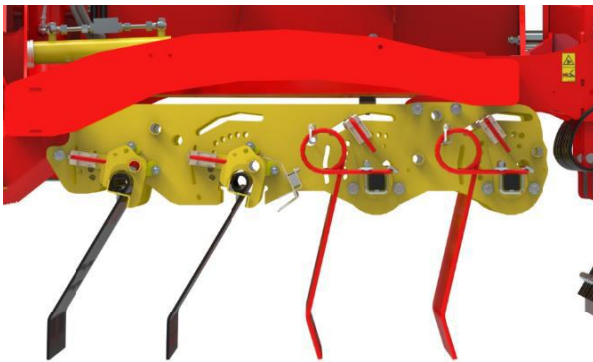

Figure 29

8.9 FOLDING LOCK

The implement has a mechanical folding lock; the locking hooks lock in place on the side frames. This becomes effective, as soon as the side frames are completely folded.

The mechanical folding lock prevents unintentional unfolding through accidental activation of the control unit or line break.



Figure 30

CAUTION!

For every folding procedure of the side frames, the operator must visually inspect the folding lock.

Road transport of the implement is only permitted if the folding lock is locked in position.

TIP!

For easier release of the folding lock, briefly charge the folding cylinder with pressure. This fully extends the folding cylinder and the side frame is again completely lifted.

8.10 TURNING ON THE HEADLAND

8.10.1 TURNING WITH ROLLER

When turning on the headland, first the lower links are lifted, then the roller is pressed downward so that the implement runs on the rollers. Lifting the lower links is required so that adequate ground clearance is ensured underneath the tine bed and so that the tines are not bent laterally.

CAUTION!

We recommend that you only use the bearing control unit of the 3-point power lift on the tractor to avoid uncontrolled depth changes on the lower links.

8.10.2 TURNING WITH CHASSIS

The implement is lifted out via the chassis, in order to subsequently turn. Here we also recommend that you lift the lower links.

NOTE!

If the hydraulic sensor for the mounted seeder is installed in the roller cylinder, the sensor will not be active when turning on the chassis. To remedy this situation

- a) a qualified specialist can mount the hydraulic sensor in the chassis cylinder.
- b) when turning, a brief, manual pressure pulse can be given to the roller cylinders, so that the seeding shaft is switched off. In this regard, note that after turning another pressure pulse must be given so that the seeding process can be resumed.

8.11 LOADING AND UNLOADING ON A LOW-BED TRAILER

Comply with the following instructions if you want to transport the implement with a low-bed trailer:

- The implement must be folded and the running gear must be lowered (see Figure 31).
- During the entire loading and unloading procedure, the implement must be lifted out as far as possible to achieve the greatest possible ground clearance.
- Set down the implement longitudinally on the low-bed trailer (see Figure 31).
- The lashing points are located on the
 - Center frame (2 lashing points)
 - Drawbar (1 lashing point)
 - Side frames (1 lashing point per frame)
 - Roller frames (1 lashing point per frame).

Each lashing point is marked with the info sign "Load Hook" (see Point 7.1).

- Firmly engage the parking brake (if present).
- Lash the wheels.

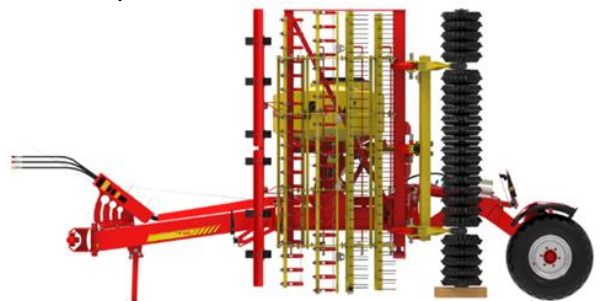

Figure 31

9 ASSISTANCE FOR FAULTS

9.1 PROCEDURE FOR FAULTS OR ERRORS

If faults are evident at commissioning or in operation or if atypical behavior occurs, contact our Service Center, see section 4 Service.

10 MAINTENANCE AND CARE

To maintain the implement in good condition, even after a longer period of operation, comply with the instructions listed below:

10.1 GENERAL MAINTENANCE INSTRUCTIONS

- In Point 6.5, you will find some basic safety regulations for maintenance tasks.
- When replacing the hydraulic hose lines, original spare parts must be used that meet the technical requirements specified by the implement manufacturer.
- Cleaning with excessive pressure can damage the paint.
- Unauthorized changes, as well as use of components and add-on parts on the implements, exclude any and all liability on the part of the manufacturer.
- Park the implement in a manner that prevents unnecessary load on the tines. (Roller all the way down, use the front parking support)
- Park the implement in a place where it is protected from the weather.
- Do not use a high-pressure cleaner to clean bearing points and hydraulic parts.
- Original parts and accessories are specifically designed for the machines, i.e. implements.
- Clean the implement with water or compressed air, however ensure that you do not use excessive pressure. Cleaning with excessive pressure can damage the paint. In particular, when using high pressure cleaners, pressure must not exceed 120 bar; cleaning water temperature must not exceed 30 °C. Do not use dirt blasters or mud blasters. The minimum distance of the spray lance to the implement is 50 cm.
- Use environmentally-friendly agents to protect the implement from corrosion during the winter.
- We expressly state that parts and accessories that are not delivered by APV are neither tested nor are they approved by APV. Consequently, installing and/or using such products can negatively alter or affect the prescribed design characteristics of your implement. The manufacturer cannot be held liable for damage that occurs due to use of non-original parts and accessories. Liability for damage resulting from the use of such parts is likewise excluded.

10.2 INSTRUCTIONS FOR REGULAR MAINTENANCE

- Retighten all bolted connections no later than after 3 operating hours, then repeat the process after approx. 20 operating hours, and perform regular inspections thereafter. Loose bolts can cause significant secondary damage that is not covered by the guarantee.
- The platform kit and its steps must be visually inspected on a regular basis.
- The hydraulic system must be inspected at least once a year by a qualified specialist.
- Regularly lubricate the lubrication points on the fold points, joints, and bearings (see Point 10.5) (with multipurpose grease approx. every 10 operating hours).
- Hydraulic hose lines must be replaced at the latest 6 years after their manufacturing date. The manufacturing date of the hydraulic hose lines is specified on the press fittings.
- Lubricate all lubrication points after cleaning, and uniformly distribute the lubricant in the bearing point (e.g. perform a brief trial run).
- After the first 10 operating hours and every 50 operating hours thereafter, check the hydraulic units (hoses and couplings) as well as pipeline for leaks and retighten the threaded connections, if necessary.

- Check the hydraulic hoses for wear, damage, and ageing before every start-up. Damaged or faulty parts must be replaced immediately.
- The wheel nuts must be checked every 50 km and retightened if necessary. The tightening torque of the wheel nuts is specified in the table below.
- Check the tire pressure before each use. Tire pressure for the respective tire dimensions are specified in the table below:

Tire dimensions	Tire pressure	Tightening torque of the wheel nuts
500-50-17	2.2 bar	320 Nm
400-60-15.5	3.4 bar	320 Nm
12.5-80-18	4.0 bar	320 Nm

10.3 REPLACING THE TINES

To replace broken or worn tines, unscrew the nuts and take down the tines.

- The new 12 mm tine, as shown in Figure 32, is hooked into the hooks and the nuts are firmly retightened. Pay attention to the proper line distance! The tines in the rear row reduce the distance of the front tines by half.
- The new 8 mm tine, as shown in Figure 33 is fixed in place with a bolt. Ensure that the bolt rests firmly on the tine and that all tines form a straight line. There must be one washer above the tine and one washer below the tine, and one washer below the receptacle.
- Always use new lock nuts.

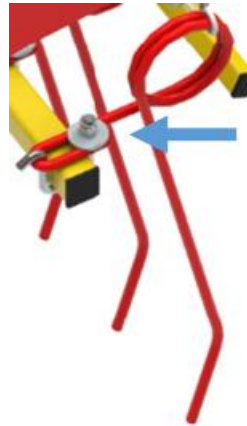

Figure 32



Figure 33

10.4 TINE SAFETY

The GP series is factory-equipped with a tine safety feature that prevents loss of the 12 mm tines by means of a rope. It protects the tines so that they do not get lost on the pasture or on the field. It also prevents damage to other implements, e.g. the mower or the baler.

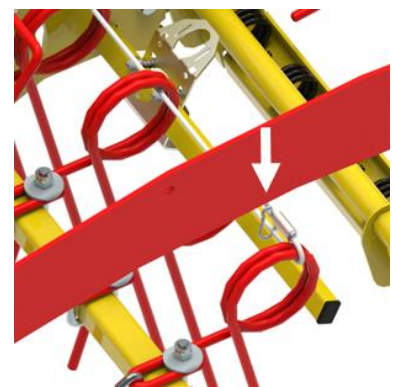

Figure 34

10.5 LUBRICATION SCHEDULE

The brake linkage on the axle must be lubricated as specified by the axle manufacturer. Note that excessive lubrication can cause grease to get into the brake drums. The following lubrication points on the fold points, joints, and bearings must be lubricated regularly with universal grease (approx. every 10 operating hours):

Quantity	Position
1	Bearing on the lower link rod, lateral slope compensation (Figure 35)
1	Bolt, pivot point when cornering (Figure 35)
4	Bearing of the side frames (2 lubrication points per frame, Figure 36)
6	Bolt and pivot point of the folding cylinder (3 lubrication points per folding cylinder; Figure 37 no. 1)
2	Bearing between chassis and frames (1 lubrication point per frame Figure 37 no. 2)
2	Pin on the chassis cylinder (Figure 38)
4	Roller bearing (2 lubrication points per frame; Figure 39)
4	Leveling plate bearing (2 lubrication points per leveling plate; Figure 40)
2	Brake linkage on the axle (1 lubrication point per tire; Figure 41)
1	Tightening spindle (if present; Figure 42)



NOTE!

Each bearing must be offloaded beforehand, so that the lubricating grease can be distributed uniformly in the bearing point.



Figure 35



Figure 36

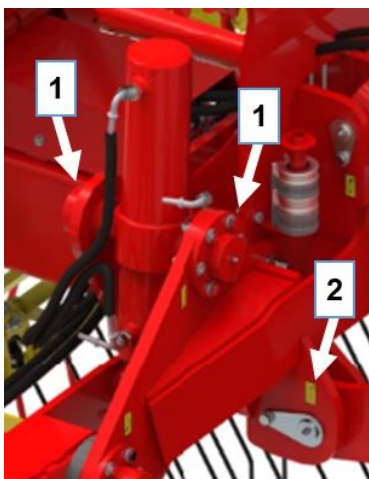

Figure 37

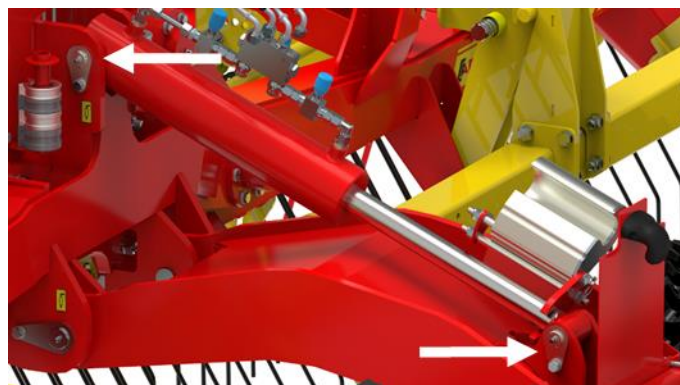

Figure 38

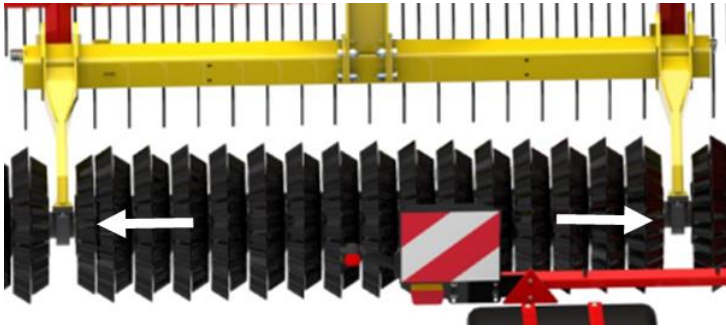

Figure 39

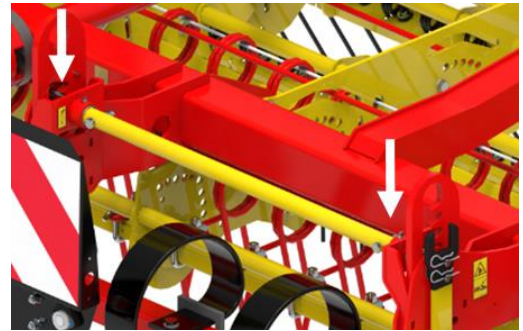

Figure 40

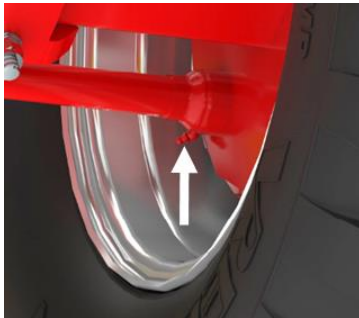

Figure 41



Figure 42

10.6 REPAIR AND CORRECTIVE MAINTENANCE

Contact the manufacturer if the implement fails or is damaged. The contact data is provided in chapter 3.

11 INFORMATION ON NATURE CONSERVATION AND ENVIRONMENTAL PROTECTION

Energy-efficient use

The tines of the implement should not penetrate into the field any deeper than necessary. This ensures that the load on the towing vehicle is no more than is strictly necessary and fuel can be saved.

Recyclable raw materials and disposal

Many parts of the implement are made of steel or spring steel (such as the center frame, side frames, etc.) and can be removed and recycled by a waste disposal company.

12 TECHNICAL DATA

type designation	GP 600 M2		
Working width	6 m		
Transport dimensions (folded) in m (HxWxD)	3.50 x 2.99 x 5.75		
Weight (toothed ring roller 410 mm and PS 500 H)	4,800 kg		
Tires (transport wheels)	500/50-17"		
Tine rows	2 rows with 12 mm tines (red) 2 rows with 8 mm tines (black)	3 rows with 12 mm tines (red)	4 rows with 8 mm tines (black)
Line spacing	75 mm (12 mm tines / red), 50 mm (8 mm tines / black)	68 mm	50 mm
Number of tines	80 units (12 mm tines / red) 120 units (8 mm tines / black)	88 units	120 tines
Brakes	2-conductor pneumatic brake		
Mounting category	CAT 3N		
Tractor power	88 kW / 120 HP		
Leading tools	Leveling is spring-suspended and height-adjustable		
Work tools	Round spring tines		
Trailing elements	Toothed ring roller d = 410 mm Cambridge roller d = 530 mm		

13 POSSIBLE COMBINATIONS WITH A PNEUMATIC SEEDER

	Dimensions HxWxD [cm]		GP weight [kg]	PS200 H	PS300 H	PS500 H	PS800 H
	Delivery Without PS	Road transport With and without PS 500	Without PS	Dimensions HxWxD [cm]			
				100x70x110	110x77x150	117x80x125	127x105x170
GP 600 toothed ring roller 410 mm	350 x 299 x 575		~ 4700	Can be combined with mounting kit for PS			
GP 600 Cambridge roller 530 mm	350 x 299 x 575		~ 4750	Can be combined with mounting kit for PS			

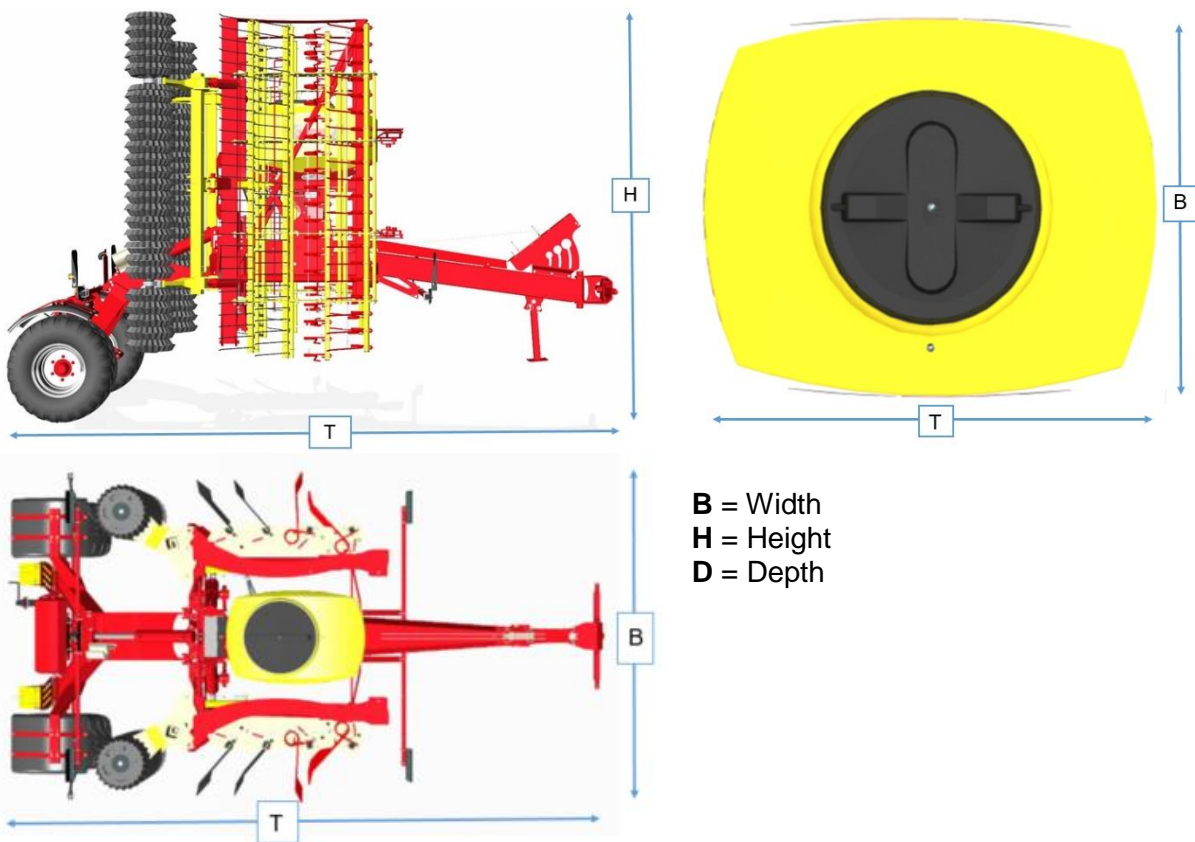

14 ROAD TRANSPORT

14.1 TRANSPORT ON PUBLIC ROADS (GENERAL INSTRUCTIONS)

- Comply with the relevant road traffic regulations in your country.
- Do not exceed the axle load and the total weight of the tractor unit.
- The implement must be labeled with country-specific warning signs or foils with white-red slanted bars (in accordance with DIN, ÖNORM or the respective country-specific STANDARDS).
- Any part posing a traffic hazard or dangerous parts (tine wheels) must be covered and additionally identified with warning signs or stickers.
- Warning signs or foils should be no higher than 150 cm above the road surface in driving operation.

- 
- Do not allow the implement to cover the tractor unit's lighting equipment; if it does the lighting equipment must be installed on the implement.
 - Do not allow the implement to impair or reduce the tractor's steerability!
 - To achieve transport position, i.e. the necessary width for road transport, the side parts as well as the rollers must be completely folded. In this regard, particularly ensure that you have not mounted too many clips on the hydraulic cylinders of the roller adjustment; if too many clips have been mounted the transport width of <: 3.0 m cannot be achieved.
 - Ensure that the folding lock is locked in place!
 - Also ensure that none of the safety splints or similar items were lost in operation.
 - Only relieve the hydraulic hoses at home by placing the tractor control unit in float position.
 - The holder for the warning signs is mounted on the center frame and the chassis.
 - For road travel, after field operation, clean off any contaminants (soil, grass, etc.) on the implement.
 - Before road transport, check to ensure that the hydraulic system and brake system are properly connected and also ensure that the parking brake is released before moving off. Check the braking effect before moving off.
 - Check for proper function of the lighting as well as good visibility of the warning signs with lighting (accessories).
 - Secure the side parts of the implement in transport position to prevent dangerous load shifts by using the folding lock provided for this purpose.
 - Adapt your driving speed to the current conditions.
 - After completely folding and locking the two securing hooks in place, the hydraulic lines must be briefly relieved so that the side parts can be securely locked in place in the securing hooks. After briefly discharging the pressure in the control unit, the control unit must be locked to ensure two levels of safety.

15 LIGHTING CIRCUIT DIAGRAM

Legend:

R	Right
1	Connector, 12 V, 7-pin
2	Right tail light
2.1	Turn signal
2.2	Tail light
2.3	Brake light
L	Left
3	Left tail light
3.1	Brake light
3.2	Tail light
3.3	Turn signal

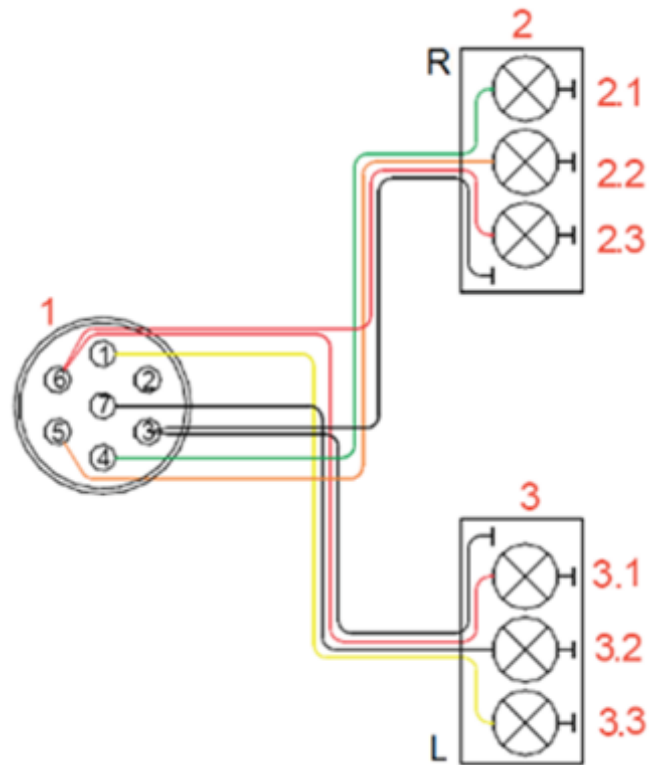

Figure 43

Connector and cable pin assignment

No	Name	Color	Function
1	L	Yellow	Left turn signal
2	54 g	---	---
3	31	White	Ground
4	R	Green	Right turn signal
5	58R	Brown	Right tail light
6	54	Red	Brake light
7	58L	Black	Left tail light

16 DECOMMISSIONING, STORAGE, AND DISPOSAL

16.1 DECOMMISSIONING THE IMPLEMENT

To ensure that the implement retains its full functionality, even during a longer period of non-operation, it is important to take precautions for storage: Comply with the information in point 16.2 in this regard.

16.2 STORING THE IMPLEMENT

- The implement must be stored in a dry and weather-protected location, so that it does not lose its functionality, even during a longer storage period.
- Uncouple the implement as specified in Point 8.2.
- Prevent the implement from rolling off unintentionally.
- Do not place or store anything on the implement.
- The implement must always be parked and stored in a secure area, to prevent unauthorized operation.



16.3 DISPOSAL

The implement and the required working materials (working materials such as hydraulic oil) must be disposed of in accordance with local waste disposal regulations for machines.

17 CROP CULTIVATION TIPS FOR USE OF THE GRASSLAND PRO HARROW

Seedbed preparation is always required before reseeding. This procedure is optimally accomplished with the Grassland Pro Harrow with 4 tine rows. Together with reconsolidation by a roller, five work procedures are accomplished in one field pass.

With its thorough and effective mode of operation, the implement can be optimally integrated into your overall cultivation concept.

The goal of your concept will be to improve yields and to multiply the valuable grasses.

Other effects of the implement, such as

- Soil aeration,
- Regulating the water balance,
- incorporation of the seed
- reconsolidation
- pressing down the seed and therefore
- promoting tillering

play a crucial role in producing a good yield of crops.

The success of weed control without chemicals and high yields, however, will for the most part depend on you, as you will be required to closely observe the processes in your soil.

Reseeding of grassland is theoretically possible during the entire frost-free and snow-free period. Gaps in the crops should already be reseeded in the spring to prevent weed competition. In principle, you should reseed more frequently and therefore work less aggressively and reduce the seed quantity.

Reseeding can be performed in the spring as soon as the soil has warmed up a little. The soil must have good trafficability, i.e. the seed should not ever be "smeared in".

Reseeding in the spring offers the advantage that the spring humidity and the disturbed soil can be used as a seedbed. However, despite the good start, grasses can dry out in a pre-summer drought, and pressure of the old sod is greater in the spring due to the stronger growth spurt.

With the Grassland Pro Harrow, we counteract this disadvantage with a roller that presses down the seed and therefore improves soil contact. This allows the seed to germinate more rapidly and the risk of desiccation is reduced.

The optimal intensity and depth setting, forward speed, type of tine adjustment, and seeding rate must be set with your understanding of the correlations between the soil properties and weather conditions, which can vary greatly in different regions.

18 ACCESSORIES

18.1 EQUIPMENT KIT FOR OPERATION ON PUBLIC TRAFFIC AREAS

This kit is required for compliance with all regulations for operation on public traffic areas.

The kit consists of the following components:

- Dual-circuit pneumatic brake system
- Wheel chocks
- Tine sections cover
- Lighting with warning signs
- Mudguard
- Anti-theft device

The listed components are described in more detail in the sub-points below.

Order number:

06028-2-282

18.1.1 COMPRESSED AIR SYSTEM

The implement is equipped with a dual-circuit pneumatic brake system. The reservoir has a capacity of 20 liters. From the tractor, the two compressed air lines (supply line and brake line) are routed to the brake valve.

From the brake valve, one line is routed to the reservoir, the other line is routed to the wheel brake cylinders.

The compressed air system is also available separately, under the following order number:

Order number:

06028-2-249

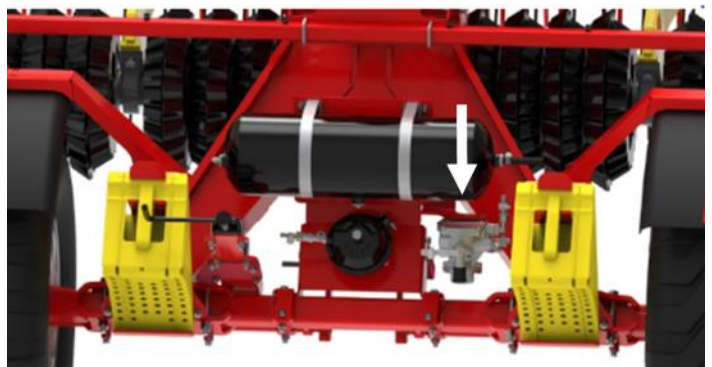

Figure 44: Symbolic image

CAUTION!

Because the brakes release immediately with the pressure tank filled, it is important to comply with the connection sequence: First couple the yellow brake line, then couple the red brake line!

TIP!

If one compressed air line on the implement should be defective, the implement can still be moved by manually triggering the pressure reservoir on the trailer brake valve (see Figure 45).



Figure 45

Note that with a vented trailer brake valve, the service brake is not active; thus the forward speed imposed by the country-specific regulations for unbraked, towed agricultural machinery, must be complied with.

18.1.1.1 DRAINING

A drain valve is provided on the underside of the reservoir. The drain valve must be activated weekly throughout the year and daily in the winter.

TIP!
Drain the air reservoir daily. Use a wire to move the pin in a lateral direction.

If the drain valve is excessively dirty, unscrew it out of the pressure reservoir and clean it thoroughly.



Figure 46

CAUTION!
The reservoir is pressurized!

18.1.1.2 READJUSTING THE BRAKE SYSTEM

A diaphragm cylinder is in the middle of the axle. The diaphragm cylinder can be readjusted using a threaded rod if necessary. The travel from activation of the cylinder to active braking must only be a maximum of one third (ca. 25 mm) of the total stroke.

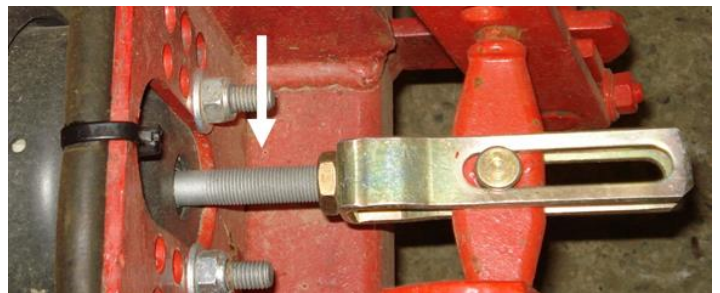

Figure 47

18.1.1.3 MEASURING THE COMPRESSED AIR

It is possible to measure the compressed air at two locations using a pressure gauge. One location is the reservoir and the other is adjacent to the diaphragm cylinder. The pressure in the reservoir must be at least 6.5 bar.



Figure 48

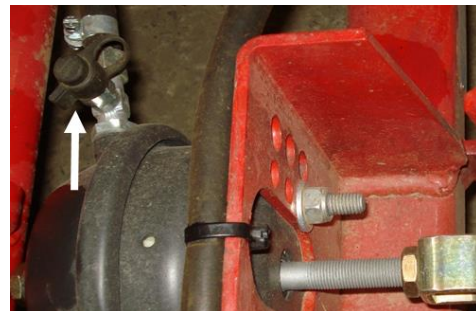

Figure 49

18.1.1.4 PNEUMATIC BRAKE SYSTEM DIAGRAM

The diagram of the dual-circuit pneumatic brake system is shown below:

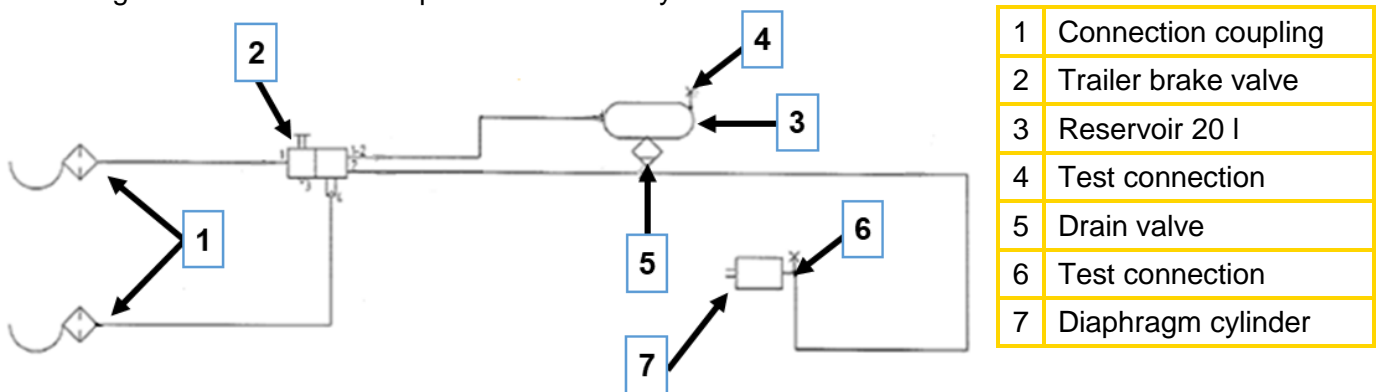

Figure 50

18.1.2 WHEEL CHOCKS

The wheel chocks prevent the implement from rolling. The wheel chocks are also available separately, under the order number:

Order number:
06028-2-251

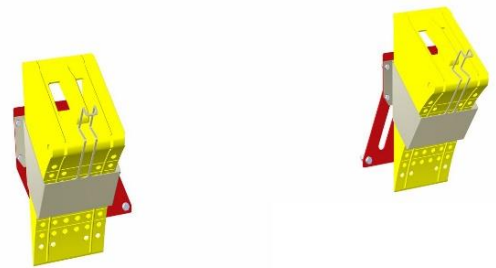

Figure 51

18.1.3 TINE SECTIONS COVER

With this protective element, the bottom tine rows of the outer tine sections are covered. The cover can be conveniently stowed for work operation. The cover is also available separately under the following order number:

Order number:
06028-2-167



Figure 52

18.1.4 LIGHTING WITH WARNING SIGNS (BOTH SIDES)

Warning signs with lighting are available as accessories for the Grassland Pro Harrow. These signs are required when the implement is transported in road traffic. The lighting / warning signs are also available separately under the following order number:

Order number:
06028-2-248



Figure 53

18.1.5 MUDGUARD

The mudguards are also available separately under the following order number:

Order number:

Tire dimensions 500/50-17": 06028-2-247

Tire dimensions 400/60-15.5" and 12.5" / 80-18": 06028-2-216

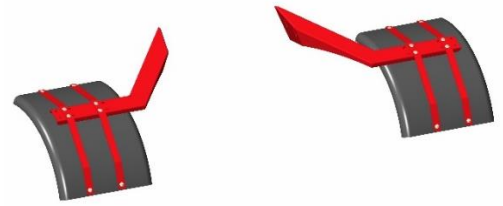

Figure 54: Symbolic image

18.1.6 ANTI-THEFT DEVICE

The anti-theft device is also available separately under the following order number:

Order number:

06028-2-262

18.2 MOUNTING KIT FOR PS 200 TO PS 500

This holder is used to mount a pneumatic seeder PS 200 to PS 500 on the implement. Please note that it must be mounted in compliance with the standards.

Order number:

06028-2-278

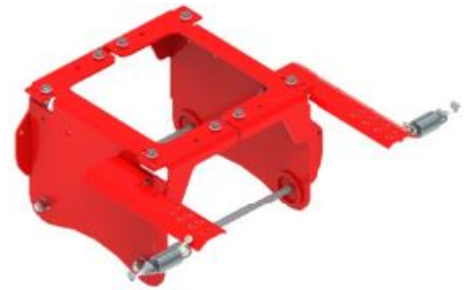

Figure 55

18.3 DISPERSION PLATE INSTALLATION

This is used to mount the dispersion plates on the Grassland Pro Harrow.

Order number:

For 8 outlets: 06028-2-276

For 16 outlets: 06028-2-277

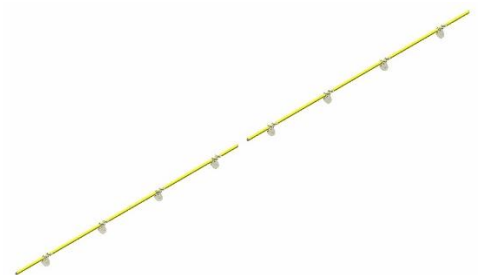

Figure 56: Symbolic image

18.4 MOUNTING KIT FOR PS 800

This holder is used to mount a PS 800 Pneumatic Seeder on the implement. Please note that it must be mounted in compliance with the standards.

Order number:

06028-2-279

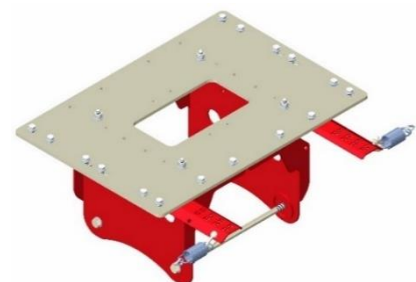

Figure 57

18.5 PLATFORM KIT

A suitable platform kit is available as an accessory for easier maintenance of the PS 200 to PS 800 Pneumatic Seeder. Please note that it must be mounted in compliance with the standards.

Order number:
06028-2-275

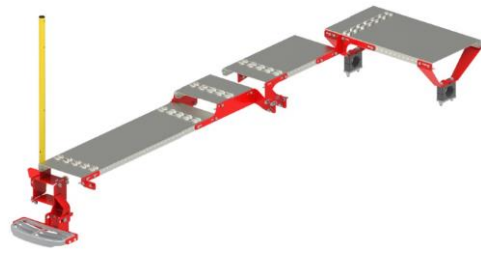

Figure 58

18.6 CHANGEOVER VALVE FOR OPERATING TWO HYDRAULIC FUNCTIONS

With the changeover valve it is possible to interconnect the hydraulic circuits of the roller frame and of the chassis. Thus, one less control unit is required. Changeover between the two hydraulic circuits occurs by activating the lever on the changeover valve, which is attached on the drawbar (see Figure 59).

Order number:
06028-2-239



Figure 59

18.7 TOOLBOX

Order number:
06028-2-283



Figure 60

18.8 SENSOR SET: GPSA + LINKAGE SENSOR

The GPSa sensor transmits the current vehicle speed to the Control Box so that the seed rate is automatically regulated. It is installed on the seeder hopper.

The linkage sensor / hydraulic sensor interrupts the metering on the headland. The sensor is mounted in the hydraulic line of the roller cylinder.

Order number:
06028-2-280





TIP!

Before driving off for the first time, calibrate the speed on the Control Box 5.2.



Figure 61

18.9 MOUNTING KIT FOR FEELER WHEELS

This kit is necessary if you want to mount or dismount the roller of the GP. It consists of

- supports for the side frames
- A maneuvering aid for the rollers, and
- feeler wheels.

The supports are mounted on the side frames. With this mounting kit the weight of the implement does not rest on the tines, and more space is available for the procedure of coupling and uncoupling the rollers.

The maneuvering aid is hooked in on the roller frame at the coupling point of the hydraulic cylinder. It acts as type of drawbar to move the roller away from the implement (uncoupling) or towards the implement (coupling) without exertion using a towing vehicle (e.g. farm loader, tractor or forklift). A position indicator on the maneuvering aid facilitates coupling of the roller.

The rollers must be replaced by pairs of feeler wheels. This provides uniform depth guidance.

Order number:

06028-2-281



Figure 62



Figure 63: Support



Figure 64: Feeler wheels



Figure 65: Maneuvering aid



Figure 66: Maneuvering aid

19 SPARE PARTS

You have the option of ordering your desired spare parts directly through our online spare parts catalog. To do so, scan the QR code with your smartphone – you will be taken directly to our online spare parts catalogue. Please have your product number / serial number on hand.

You can also access our online spare parts catalog on our website www.apv.at in the Service area.

For questions concerning spare parts or your order, our customer service organization (see point 4 Service for contact data) would likewise be happy to assist you.



20 INDEX

Accident prevention regulations.....	8	Maintenance	28
Adjusting the series of holes.....	24	Mode of operation of the implement.....	19
Bracket for PS	40	Operating Manual	19
Combination possibilities	33	Parking support.....	21
Compressed air system defective.....	37	platform kit	41
Connection of the compressed air system	37	Production number.....	6
Connection of the hydraulic hoses.....	10, 21	Recyclable raw materials	31
Connection of the pneumatic brake system ...	20, 22	Repair.....	31
Coupling the implement.....	20	Replacing the tines	29
Crop cultivation tips	36	Road transport	33
Decommissioning	35	Roller	25
Disposal	36	Safety instructions.....	7
Drawbar adjustment	23	Service.....	6
EC Declaration of Conformity	4	Service address	6
Energy-efficient use.....	31	Shear guard.....	25
Folding	23	Spare parts	43
Folding lock	26	Storage	35
GPSa sensor	41	Structure of the implement	19
Hydroclips	23	Technical data	32
Identification	6	Tine safety	29
Information signs	16	Tire pressure.....	29
Intended use	7	Turning	27
Lashing points	27	type designation.....	32
levelling plate	24	Type plate	6
Lighting.....	35	Uncoupling the implement.....	21
Linkage sensor	41	Unfolding	22
Loading and unloading	27	Warning signs with lighting.....	39
Lubrication points	29	Warranty	7
Lubrication schedule.....	29	Warranty activation	7
		Working depth.....	23



APV – Technische Produkte GmbH
Headquarters: Dallein 15
3753 Hötzelsdorf, Austria

Tel.: +43 2913 8001
office@apv.at
www.apv.at

