

# GRASSLAND COMBI GK 400 M1

OPERATING MANUAL



**PLEASE READ CAREFULLY BEFORE INITIAL OPERATION!**

Translation of the original operating instructions

Version: 1.2 EN; item number: 00602-3-225



## TABLE OF CONTENTS

<b>1</b>	<b>EC DECLARATION OF CONFORMITY</b> .....	<b>4</b>
<b>2</b>	<b>UK CONFORMITY ASSESSED</b> .....	<b>5</b>
<b>3</b>	<b>IDENTIFICATION OF THE IMPLEMENT</b> .....	<b>6</b>
<b>4</b>	<b>SERVICE</b> .....	<b>6</b>
<b>5</b>	<b>WARRANTY</b> .....	<b>6</b>
5.1	Warranty activation .....	7
<b>6</b>	<b>SAFETY INFORMATION</b> .....	<b>7</b>
6.1	Intended use .....	7
6.2	General safety-related instructions and accident prevention regulations .....	7
6.3	Mounted implements .....	9
6.4	Hydraulic system .....	9
6.5	Maintenance .....	9
6.6	Tyres .....	10
6.7	Mounted seeders .....	10
6.7.1	Filling the seeder .....	10
<b>7</b>	<b>INFORMATION SIGNS / HAZARD LABELS</b> .....	<b>11</b>
7.1	Information signs .....	11
7.2	Hazard labels .....	12
<b>8</b>	<b>OPERATING MANUAL</b> .....	<b>12</b>
8.1	Mounting on the tractor .....	12
8.2	Separate operation .....	13
8.3	Layout and mode of operation .....	16
<b>9</b>	<b>WORKING POSITION AND SETTING THE WORKING DEPTH</b> .....	<b>16</b>
9.1	depth adjustment .....	16
9.2	Aggressiveness adjustment .....	17
9.3	Levelling plate .....	17
9.4	Use of individual tools .....	18
<b>10</b>	<b>MAINTENANCE AND CARE</b> .....	<b>18</b>
10.1	General maintenance instructions .....	18
10.2	Regular maintenance instructions .....	18
10.3	Changing the tines .....	19
10.4	Tine safety .....	19
10.5	Repairs and service .....	19
<b>11</b>	<b>INFORMATION ON NATURE CONSERVATION AND ENVIRONMENTAL PROTECTION</b> .....	<b>19</b>
<b>12</b>	<b>TECHNICAL DATA</b> .....	<b>20</b>
<b>13</b>	<b>HYDRAULIC DIAGRAM</b> .....	<b>21</b>
<b>14</b>	<b>ROAD TRANSPORT</b> .....	<b>21</b>
14.1	Transport on public roads (general information) .....	21
14.2	Transport on public roads (most important specifications) .....	21
14.3	Calculation of the weight ratios .....	22
14.3.1	Table for the weight ratios .....	23

<b>15</b>	<b>LIGHTING CIRCUIT DIAGRAM</b> .....	<b>23</b>
<b>16</b>	<b>DECOMMISSIONING, STORAGE AND DISPOSAL</b> .....	<b>24</b>
16.1	Decommissioning the implement .....	24
16.2	Storage of the implement .....	24
16.3	Disposal .....	24
16.4	Crop cultivation tips when using the GK 400 M1 .....	24
<b>17</b>	<b>ACCESSORIES</b> .....	<b>25</b>
17.1	Lighting with warning signs (on both sides) .....	25
17.2	Platform kit for the harrow .....	25
17.3	Accessories kit for dispersion plate installation for the harrow .....	26
17.4	Pneumatic Seeder mounting kit for the harrow .....	26
17.5	Multi-Metering System mounting kit for the harrow .....	26
17.6	Sensor set - GPSa + Linkage sensor top link .....	26
<b>18</b>	<b>SPARE PARTS</b> .....	<b>27</b>
<b>19</b>	<b>INDEX</b> .....	<b>27</b>

# 1 EC DECLARATION OF CONFORMITY



according to Machinery Directive 2006/42/EC



APV-Technische Produkte GmbH  
Dallein 15  
A-3753 Hötzelsdorf

hereby declares that the following mounted implement complies with the applicable basic safety and health requirements of the above-mentioned Directive in terms of their concept and design as well as the versions put on the market.

This declaration loses its validity if there are any changes to the mounted implement that are not approved by APV-Technische Produkte GmbH.

Designation of the mounted implement:

**GRASSLAND COMBI GK 400 M1**

Year of manufacture: as of 2020

Serial number(s): as of 06023-01000

Applied relevant EC Directives:  
Machinery Directive 2006/42/EC

For the planning, design, construction and marketing of the mounted implement, the following harmonised European standards were applied in addition to the Directives, in particular:

- EN ISO 12100:2010 – Safety of machinery, general principles for risk assessment
- EN ISO 13857:2020 – Safety distances to prevent hazard zones being reached by upper and lower limbs
- ISO 13849-1:2015 – Safety of machinery - Safety-related parts of control systems

Responsible for the technical documentation: Planning and Design department, Dallein 15

Ing. Jürgen Schöls  
Managing director  
(authorised person in the EU)

Dallein/Hötzelsdorf, 11/2022

## 2 UK CONFORMITY ASSESSED

according to Machinery Directive 2006/42/EC



APV-Technische Produkte GmbH  
Dallein 15  
A-3753 Hötzelstdorf

hereby declares that the following mounted implement complies with the applicable basic safety and health requirements of the above-mentioned Directive in terms of their concept and design as well as the versions put on the market.

This declaration loses its validity if there are any changes to the mounted implement that are not approved by APV-Technische Produkte GmbH.

Designation of the mounted implement:

**GRASSLAND COMBI GK 400 M1**

Year of manufacture: as of 2020

Serial number(s): as of 06023-01000

Applied relevant EC Directives:  
Machinery Directive 2006/42/EC

For the planning, design, construction and marketing of the mounted implement, the following harmonised European standards were applied in addition to the Directives, in particular:

- EN ISO 12100:2010 – Safety of machinery, general principles for risk assessment
- EN ISO 13857:2020 – Safety distances to prevent hazard zones being reached by upper and lower limbs
- ISO 13849-1:2015 – Safety of machinery - Safety-related parts of control systems

Responsible for the technical documentation: Planning and Design department, Dallein 15

A handwritten signature in black ink, appearing to read 'Jürgen Schöls'. The signature is fluid and cursive, written over a white background.

Ing. Jürgen Schöls  
Managing director  
(authorised person in the EU)

Dallein/Hötzelstdorf, 11/2022

### 3 IDENTIFICATION OF THE IMPLEMENT

The Grassland Combi can be clearly identified by the following information on the type plate.

- Designation
- Model
- Production number

#### Position of the type plate

The type plate is found on the main tube beside the mounting frame bracket.

The following image (Fig. 1) shows the layout of the type plate:



Fig. 1

The data on the type plate have the following meaning:

- 1: Designation
- 2: Model
- 3: Product number / serial number
- 4: Weight
- 5: Year of manufacture



#### PLEASE NOTE!

In cases of inquiries or warranty claims, please always tell us the production number / serial number of your implement.

### 4 SERVICE

Please contact our service address in the following cases:

- If you still have questions regarding the handling of this implement despite the information provided in this operating manual
- For questions regarding spare parts
- To order maintenance and repair work

#### Service address:

APV - Technische Produkte GmbH  
ZENTRALE  
Dallein 15  
A-3753 Hötzelstdorf  
AUSTRIA

Telephone: +43 (0) 2913 8001-5500  
Fax: +43 (0) 2913 8002  
Email: [service@apv.at](mailto:service@apv.at)  
Web: [www.apv.at](http://www.apv.at)

### 5 WARRANTY

Please check the implement for any transport damage immediately upon receipt. Later claims regarding transport damage can no longer be considered.

We grant a six-month factory warranty starting on the date of delivery and based on a warranty activation (see Point 5.1). Your invoice or the delivery slip serve as a warranty certificate.

This warranty is applicable for cases of material or construction faults and does not include parts that are damaged by normal or excessive wear.

The warranty expires

- if damage is caused by external forces.
- in cases of operating errors.
- if the kW/HP limits are significantly exceeded.
- if the implement is modified, expanded or equipped with third-party spare parts without our permission.

## 5.1 WARRANTY ACTIVATION

Every APV implement must be registered immediately after delivery. The registration activates the claim for warranty services and APV can guarantee the best service. To activate the warranty for your implement, simply scan the QR code with your smartphone - you will then be taken directly to the service area on our website.



Of course, you can also activate the warranty through our website [www.apv.at](http://www.apv.at) in the service area.

## 6 SAFETY INFORMATION

**This chapter contains general rules of conduct for the intended use of the implement and safety-related information that should always be observed for your safety.**

The list is very extensive, and some of the information does not apply exclusively to the delivered implement. However, the summary of the information often reminds you of unconsciously neglected safety regulations for the everyday operation of machines and implements.

### 6.1 INTENDED USE

**The Grassland Combi GK 400 M1 is intended as a rear-mounted implement and is designed and built for use in agricultural operations. It is used to prepare the soil for subsequent tillage and use.**

Any other use is considered to be non-intended. The manufacturer is not liable for any resulting damage, the operator alone bears the associated risk.

Intended use also includes compliance with the conditions for operation, maintenance, and repairs prescribed by the manufacturer.

The implement may only be used, maintained and repaired by persons who have relevant experience and were instructed on the risks. The safety instructions must also be handed over to other users.

The applicable country-specific accident prevention regulations as well as the other generally safety-related, occupational health and road traffic regulations must also be observed.

The manufacturer is not liable for any damage resulting from unauthorised modifications and the use of components and auxiliary parts. This causes the declaration of conformity to lose its validity.

The Grassland Combi is intended for outdoor operation in dry weather, within a temperature range from +5 °C to 40 °C. Water ingress must be prevented. Do not use the Grassland Combi in rainy conditions!

### 6.2 GENERAL SAFETY-RELATED INSTRUCTIONS AND ACCIDENT PREVENTION REGULATIONS

- The operator has read and understood this operating manual before handling the implement.
- The operating company must train and instruct their personnel based on this operating manual, if necessary. The personnel must have read and understood this operating manual before handling the implement.
- Always keep the operating manual close to the implement for reference purposes.
- When passing on the implement, be sure to pass on the operating manual.

- Do not use the implement if you are tired or under the influence of drugs, alcohol or medication.
- **Check the implement and the tractor for road and operational safety before every use (e.g. defective parts, connections, hoses, etc.)!**
- Inspections before and during operation as well as regular care and maintenance of the implement must be performed.
- **Before starting work, get to know all of the equipment and operating elements as well as their functions. It is too late to do so during operation!**
- The general applicable safety and accident prevention regulations of the respective countries must be observed.
- Always secure the parked implement against unintentional rolling.
- The implement may only be used by persons who are informed of the hazards and who know the regulations for transport on public roads. The operator must check the suitability/driving licence of their personnel regularly.
- The warning and information signs applied to the implement provide important instructions for safe operation, observe them for the sake of your own safety!
- The implements must be checked regularly by the operator (before every use) for any fractures and cracks, chafe marks, leaks, loose bolts and connections, vibrations, unusual sounds, and to ensure they function correctly.
- Observe the respective country-specific road traffic regulations when using public roads!
- The user should wear close-fitting clothing. Avoid wearing loose clothes!
- To reduce the risk of fire: Keep the implements clean!
- Before starting up and operating the implement: Check the surrounding area! (Children!) Ensure sufficient visibility!
- It is not allowed to carry passengers on the mounted implement! This has to be checked by the operator before every use.
- It is forbidden to transport working materials on the implement!
- The implement must be coupled according to the instructions and only onto the specified devices!
- Special care must be taken when coupling and uncoupling implement to and from the tractor!
- When mounting and dismounting, put the support devices in their respective positions! (Stability)
- Always attach ballast weights at the intended attachment points according to the specifications!
- Observe the permissible axle load, total weight and transport dimensions!
- Transport equipment - e.g. lighting, warning signs and any protective equipment, must be checked and mounted!
- Triggers for fast couplers must be hanging loosely and must not trigger themselves when lowered.
- Never leave the driver's platform while driving!
- The driving behaviour, steering and braking capacity are also affected by mounted or towed implements and ballast weights. For this reason, always ensure sufficient steering and braking capacity!
- When driving in curves, take account of the wide radius and/or the centrifugal mass of the implement (pay attention to the minimum turning curve)!
- The implement may only be operated when all of the protective devices are installed and in safety position!
- **It is forbidden to stand in the working area of the implement!**
- **Do not stand near rotating and swivelling parts of the implement!**
- Hydraulic folding frames may only be actuated when nobody is standing in the swivelling range.
- There are pinch and shear points on externally powered (e.g. hydraulic) parts!
- On implements with manual folding, always ensure that the implement is stable!
- Danger after lifting due to centrifugal mass that is still rotating! Only approach the implement when it has come to a standstill!
- Before exiting the tractor, lower the implement onto the ground, switch off the motor and remove the ignition key!
- Standing between the tractor and the implement is forbidden unless the vehicle is secured against rolling away using the parking brake and/or with wheel chocks!
- Folded frames and lifting devices must be locked in transport position!



- Safety glasses, hearing protection and safety shoes must be used.

### **6.3 MOUNTED IMPLEMENTS**

- Before mounting and dismounting implements on the three-point linkage, move the operating devices into the position that excludes unintentional lifting or lowering!
- For three-point mounting, the mounting categories of the tractor and the implement must match or be adapted!
- There is a risk of injury due to crushing and shearing points in the area of the three-point linkage!
- Do not stand between the tractor and the implement when actuating the external controls for the three-point mounting!
- When the implement is in transport position, always ensure that the tractor three-point linkage is sufficiently locked to the sides!
- When driving on roads with the implement lifted, the operating lever must be locked against lowering!

### **6.4 HYDRAULIC SYSTEM**

- **Inspect the hydraulic hose lines at regular intervals and replace in case of damage or wear! The replacement lines must comply with the technical requirements of the implement manufacturer!**
- The hydraulic system is under high pressure!
- When connecting hydraulic cylinders and motors, the specified connection of the hydraulic hoses must be observed!
- When connecting the hydraulic hoses to the tractor hydraulic system, make sure that the hydraulic system on the tractor and implement side is unpressurised!
- For hydraulic function connections between the tractor and the implement, coupling sleeves and connectors should be marked to rule out operating errors! If the connections are interchanged, the function will be inverted! (e.g. lifting/lowering) – Risk of accident!
- Due to the risk of injury, use suitable tools when searching for leaks!
- Liquids escaping under high pressure (hydraulic oil) can penetrate skin and cause serious injuries! Consult a doctor immediately in case of injury! (Risk of infection!)
- Before working on the hydraulic system: Park the implement, depressurize the system and switch off the motor!
- The securing chain should only be unhooked when it is relieved of tension! (cylinder must be filled with oil)

### **6.5 MAINTENANCE**

- Maintenance, repair, and cleaning work as well as the elimination of malfunctions should always be performed when the drive is switched off and the motor is at a standstill (remove the ignition key) and the implement is uncoupled from the towing vehicle!
- The maintenance work itself may only be performed by trained specialist personnel and may never be performed alone.
- Extreme caution must be taken when changing defective components or tools. Replacing components that cannot be removed with tools such as a screwdriver or wrench may only be replaced by specialist personnel from an appropriately authorised company or by APV Customer Service.
- If repairs or maintenance are required on the implement that can only be performed in conjunction with the towing vehicle, this work must be identified by a clearly visible information sign "Caution: maintenance work".
- Check the nuts and bolts regularly for tight fit and retighten if necessary!
- When performing maintenance on the lifted implement, always ensure safety through suitable support elements!
- When changing work tools with sharp edges, always use suitable tools and gloves!
- Properly dispose of oils, grease and filters!
- Always cut the power supply when working on the electrical system!

- 
- When performing electrical welding work on the tractor and mounted implement, disconnect the cable on the generator and the battery!
  - Spare parts must at least comply with the technical requirements specified by the implement manufacturer! This is ensured with original parts!

## **6.6 TYRES**

- When working on the tyres, it must be ensured that the implement is safely parked and secured against rolling away and tipping (wheel chocks).
- The mounting of wheels and tyres requires sufficient knowledge and proper installation tools.
- Repair work on the tyres may only be performed by specialists and with suitable installation tools.
- Check the inflation pressure regularly. Observe the prescribed inflation pressure (2.1 bar)!

## **6.7 MOUNTED SEEDERS**

- When using a seeder, all of the specifications of the implement manufacturer must be observed.
- The seeder can be easily reached with using a ladder and platform. They must be clean and dry during use.
- It is strictly forbidden to stand on the platform or its access ladder while driving.
- When not in use, the ladder must be folded up and secured.

### **6.7.1 FILLING THE SEEDER**

- The seeder is filled using a supply vehicle.
- The platform kit may not be used to fill the seeder or as a storage area for objects or seed. When filling the seeder, never stand under a suspended load!
- When driving up to the implement with seed, nobody may be standing on or around the implement.
- The platform kit may only be accessed to open the seed sacks when the load has been stabilised above the opening of the seed hopper.
- During the loading procedure, avoid any contact with the treated seed and wear gloves, a dust mask and safety glasses.





**CAUTION!**  
Misprints, errors and omissions excepted!

## 7 INFORMATION SIGNS / HAZARD LABELS





Pay special attention to these stickers on the implement, as they warn you of specific dangers!

### 7.1 INFORMATION SIGNS

 <p>Read and observe the operating manual before operating the implement!</p>	 <p>Do not stand on the implement while driving!</p>	 <p>Loading hooks. When loading the implement, attach the ropes or chains to these points!</p>	 <p>Always switch off the engine and remove the key before maintenance work!</p>
--	---	--	---

 <p>After a short period of operation, re-tighten all bolts and nuts.</p>	 <p>Labelling of the grease nipple position.</p>	 <p>Label for the recess for installing the 24-mm pins.</p>
--	---	---

## 7.2 HAZARD LABELS

			
<p>Be careful with escaping high-pressure liquids! Observe the instructions in the operating manual!</p>	<p>Do not stand between the machines when connecting the implements and actuating the hydraulic system!</p>	<p>Do not climb onto rotating parts, use the intended access ladders!</p>	<p>Caution, crushing area! Never reach into the crushing danger zone as long as the parts could still move!</p>

<p>Danger due to parts being flung out; Observe the safety distance!</p>

## 8 OPERATING MANUAL

### 8.1 MOUNTING ON THE TRACTOR

- The air pressure in the rear tractor tyres should be **0.8 bar** during operation. If the tyres have a lower load capacity, increase the pressure.
- Under difficult operating conditions, additional wheel weights can be useful. Please also refer to the operating manual from the tractor manufacturer.
- The tractor should be equipped with sufficient ballast weight at the front to ensure the steering and braking capacity. At least 20 % of the empty vehicle weight is required on the front axle.
- The lifting links must be adjusted to the same height on the left and on the right.
- Mount the implement on the 3-point linkage of the tractor.
- Mount the top link so that it slants down towards the tractor during operation. Also refer to the sticker on the implement (observe the specification of the tractor manufacturer).
- After coupling the lower link, turn around the parking support by pulling out the pin, reposition it and then secure. (Fig. 2; Fig. 3)



Fig. 2



Fig. 3

- Connect the hydraulic hoses to a double-acting control unit. During connection, make sure that the hoses are unpressurised both on the tractor and implement sides.

**PLEASE NOTE!**  
 To ensure correct connection, the hydraulic hoses are labelled as follows:  
 → 1 red cable tie: cylinder extends (A in Fig. 4),  
 → 2 red cable ties: cylinder retracts (B in Fig. 4).

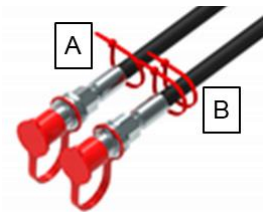

Fig. 4

## 8.2 SEPARATE OPERATION

The harrow and the roller of the Grassland Combi can be disconnected and the implements can be used separately.

**CAUTION!**  
 The Grassland Combi, as the entire implement and in separate operation, may only be operated on the 3-point hitch at the rear of the tractor.

**Proceed as follows:**

- Lift the implement until the roller no longer has contact with the ground.
- Move all of the supports for the roller to an optimal position to park the roller safely.

**TIP!**  
 To have more clearance for the uncoupling procedure, turn the harrow rows up (Fig. 5).

**TIP!**  
 The supports on the roller frame must be pushed all the way up in the guide and fixed with the locking pins (see Fig. 6).

**TIP!**  
 The second support is integrated in the seed drill bracket (see Fig. 7).

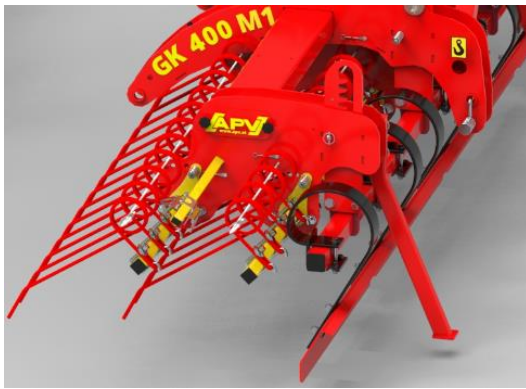

Fig. 5



Fig. 6



Fig. 7

- Now remove the 4 short, 16 mm-thick pins (Fig. 8) and fold down the pin lock.

### CAUTION!

The continuous 28 mm connecting pins must NOT be removed for now!

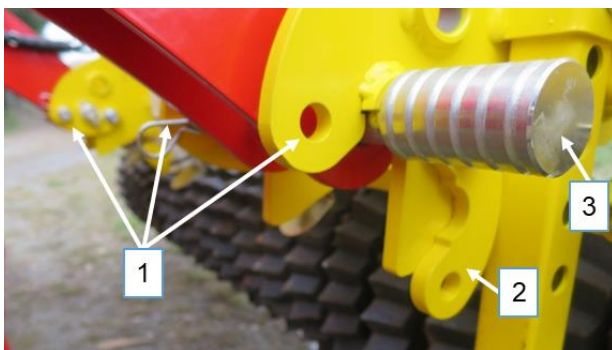

Fig. 8

- 1: 16 mm pin
- 2: Pin lock
- 3: Continuous 28 mm connecting pin

- Carefully lower the implement until the roller is stable, then relieve the roller cylinder so that the pin can be pulled out.



### TIP!

To prevent paint damage, remove the roller cylinder.

- Disconnect the plug connection for the wiring harness on the tractor side and open the releasable cable ties on the harrow frame. The wiring harness is then only still fastened to the roller. Install the top link sensor from the harrow onto the roller.
- Now carefully lower the harrow until the connecting pins for the roller are completely released from the roller frame. Now you can slowly drive forward and uncouple the harrow.
- Insert the connecting pins from the harrow in the roller frame. If you want to couple the roller, you still have to use the fitting balls with the supplied spacer bushings (Fig. 9).

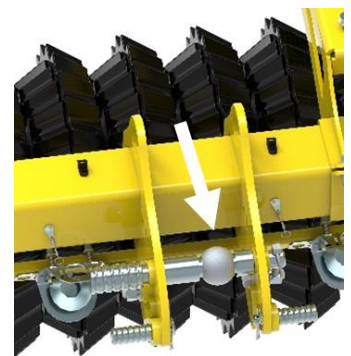
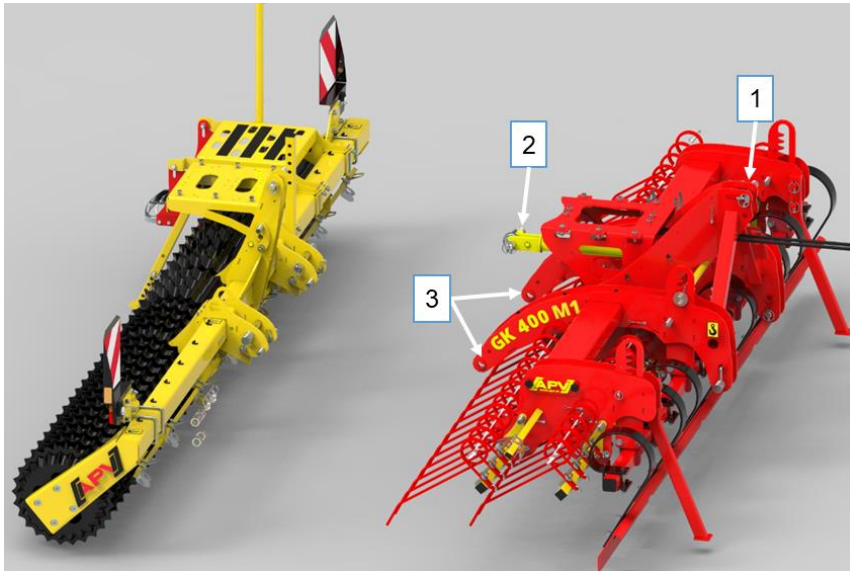

Fig. 9



- 1: Top link sensor
- 2: Roller cylinder
- 3: Connecting pin

Fig. 10



**TIP!**

If you are using the roller in conjunction with a pneumatic seeder, position the parking support in the intended parking position (in the hollow profile of the roller frame). This prevents impact of the seed on the support and therefore an uneven spread pattern.

The 3-point hitch must be used to mount the roller on the tractor. In doing so, it must be ensured that the top link is always installed in the topmost hole (number 1 in Fig.: 11).



**PLEASE NOTE!**

To install the roller on the harrow, 25 mm and 24 mm pins are used. Since the pin dimensions can hardly be distinguished visually, the 24 mm pins are marked with a yellow shrink hose (number 2 in Fig.: 11). Moreover, each recess for installing a 24 mm pin is marked with a round yellow sticker (number 3 in Fig.: 11).

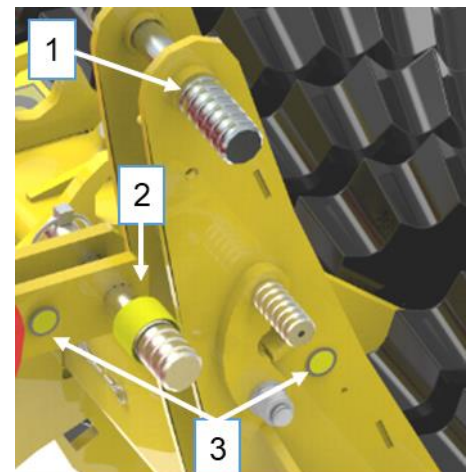
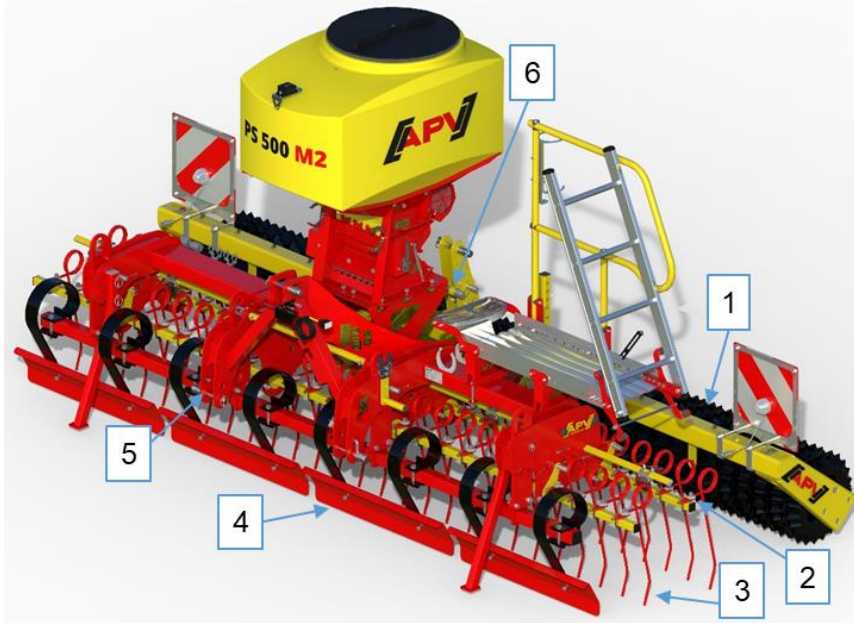

Fig.: 11

## 8.3 LAYOUT AND MODE OF OPERATION



- 1: Toothed Ring Roller
- 2: Tine holder
- 3: Tines 10 mm or 12 mm
- 4: Levelling plate
- 5: Cat II three-point linkage
- 6: Roller cylinder

Fig. 12

Thanks to its robust and compact design, the Grassland Combi GK 400 M1 is ideal for new seeding, reseeding, and controlling weeds on grassland.

The height-adjustable levelling plate removes coarse unevenness in the grassland and spares the tines unnecessary strain.

Due to the tight line distances of the individual tines (72.5 mm for 10 mm or 12 mm tines), the sward is optimally prepared and the plants can germinate rapidly after reseeding. With the high contact pressure of the utilised roller, seed soil contact is improved and the nutrient supply to the reseeded plants is optimised. To obtain the best possible rolling results, a forward speed of 8 km/h should not be exceeded. A speed of 6-12 km/h is ideal for grassland.

## 9 WORKING POSITION AND SETTING THE WORKING DEPTH

### 9.1 DEPTH ADJUSTMENT

To adjust the depth of the GK 400 M1, 2 work steps are required.

- Depending on how aggressively you want to till the soil, slightly extend or retract the cylinder to transfer the weight of the roller onto the harrow tines.
- The lower link must be positioned such that the frame of the implement is horizontal to the field. Reference points for this are the shaped tube (160 x 80 mm) or the pneumatic spreader (this should be positioned vertically to the field).

During operation, the top link on the implement side must always be attached in the elongated slot. For normal operation, the pin should be in the middle of the elongated slot.

If you want to use the GK 400 M1 with the roller lifted, i.e. the roller in the highest position and the roller cylinder completely retracted, you must firmly attach the top link on the implement side. This position must also be used in road traffic.



## 9.2 AGGRESSIVENESS ADJUSTMENT

In addition to the depth, the aggressiveness of the tines relative to one another on the GK 400 M1 can also be changed. To do so, you only have to insert the pins for the harrow rows as desired in a higher or lower hole. (number 1 in Fig. 13)

This makes it possible to adjust the 2 harrow rows with 12 (10) mm tines at different degrees of aggressiveness. This also allows for compensation of various degrees of wear on the tines.

The two rows of tines tear open the sward and produce an optimal seedbed for the new grasses. If the front row of tines should work more aggressively (e.g. under hard soil conditions), you must place the pin in one of the top holes at the rear. In this way, the aggressiveness of two rows can be adjusted independently.

For this purpose, you can select one of seven levels. At an optimal forward speed, the tines make an elliptical motion. The steeper the position of the tines, the smaller the motion. The flatter the position of the tines, the larger the motion. If the sward is dense and intense tillage is required, the tines should be positioned more steeply (see Fig. 13).

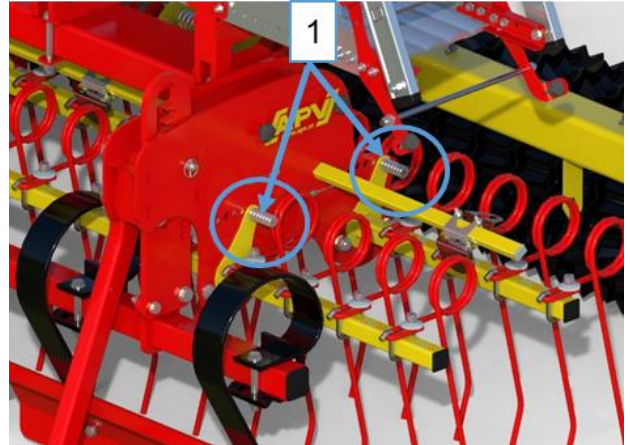

Fig. 13

## 9.3 LEVELLING PLATE

The levelling plate eliminates molehills after the winter and serve to roughly level the grassland. The height should be adjusted so that it runs along the sward just above the ground. It should not scratch into the sod. However, if the sod is very uneven, allowing the levelling board to slightly penetrate into the soil can improve the levelling effect on the long term. To adjust the working height, remove the (4 pcs.) locking pins, crank the levelling plate to the desired height, and fix it again with the 4 pins. (Fig. 14)



### TIP!

**Remove the two pins on the right first, and then the two left pins, so that you can lift the levelling plate more easily with the crank.**



Fig. 14

The levelling plate has a shear-off safety to prevent damage to the frame due to excessive loads on the levelling plate.

The implement accessories include 3 sets of shear bolts. When these have been used, attention must be paid to the quality of the replacement bolts. Only M12x60 bolts with a quality of 4.6 may be used.

The tightening torque of 10 Nm for the M12 bolts may not be exceeded. If the M16 bolts behind have become loose, a maximum tightening torque of 15 Nm must be observed (Fig. 15).



Fig. 15

## 9.4 USE OF INDIVIDUAL TOOLS

With GK 400 M1, it is also possible to use individual tools (levelling plate, harrow, roller) separately or in any combination, e.g. you can use the roller alone by completely extending the roller cylinder. In this way, you can also use the implement on field crops for rolling after seeding.

If you only want to level and roll, position the roller and the levelling plate all the way down so that the harrow rows are lifted off the ground. In addition, fix the rows of tines in the first or lowest hole.

# 10 MAINTENANCE AND CARE

## 10.1 GENERAL MAINTENANCE INSTRUCTIONS

To maintain the implement in good condition even after a long service life, the following instructions must be observed:

- **Before every operation, check the hydraulic hose lines for wear, damage and ageing.**
- When replacing the hydraulic hose lines, lines must be used that comply with the technical requirements of the implement manufacturer.
- In Point 6, you will find some basic safety regulations for maintenance work.
- Original parts and accessories are designed especially for the machines or implements.
- Please note that spare parts and accessories not supplied by us have also not been tested and approved by us.
- The installation or use of such products can therefore possibly negatively change or impede the constructional properties of your implement. The manufacturer rules out any liability for damages resulting from the use of non-original parts and accessories.
- The manufacturer is not liable for any unauthorised modifications and the use of components and auxiliary parts.
- After cleaning, lubricate all of the grease points and distribute the grease evenly in the bearing points (e.g. perform a short test run).
- Do not use a high pressure cleaner to clean bearing and hydraulic parts.
- The paint can be damaged by cleaning with excessive pressure.
- During the winter, the implement should be protected against rust with an environmentally-friendly product.
- Park the implement protected from weather conditions.
- Put down the implement in a way that the tines are not needlessly strained (roller all the way down, use the parking supports at the front).

## 10.2 REGULAR MAINTENANCE INSTRUCTIONS

- All bolted connections should be re-tightened at the latest after 3 operating hours and again after 20 hours, and then checked regularly (loose bolts can cause significant consequential damage, which is not covered by the warranty).
- The grease points on the joints and bearings must be lubricated regularly (approx. every 10 operating hours with universal grease).
- Regular visual inspection of the tine safety must be performed.
- For implements with fast coupler, the guide slots must also be lubricated.
- After the first 10 operating hours and subsequently every 50 operating hours, the hydraulic units, hydraulic hoses and couplings must be checked for leaks and the bolted connections must be tightened if necessary.
- **Hydraulic hose lines must be replaced at the latest 6 years after their manufacturing date. The manufacturing date of the hydraulic hose lines is specified on the fittings.**
- The platform kit and its access ladder must be visually inspected on a regular basis.
- The rubber for fastening the access ladder of the platform kit must be checked regularly for wear and replaced if necessary. It should only be replaced by trained specialist personnel and with original parts.

## 10.3 CHANGING THE TINES

To replace broken or worn tines, all you have to do is loosen the nut and take out the tine (10 or 12 mm tines).

- As shown in Fig. 16, you must hook on the new 10 or 12 mm tines and re-tighten the nuts.
- Pay attention to the proper line distance! The tines in the rear row cut the distance of the front tines in half.

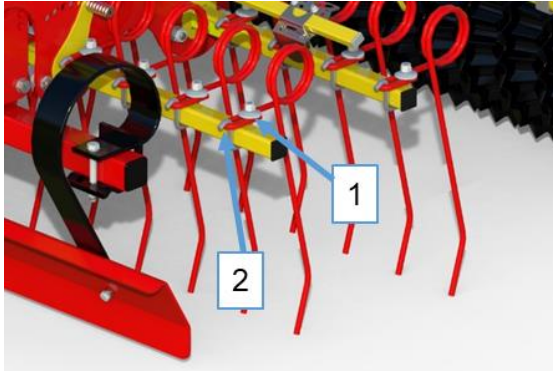

- 1: Unscrew the nut
- 2: Hook for fixing

Fig. 16

## 10.4 TINE SAFETY

As a standard, the GK series is equipped with a tine safety by means of a rope. It protects the tines so that they do not get lost on the pasture or on the field. This also prevents damage to other implements, e.g. the mower or the baler.



Fig. 17

## 10.5 REPAIRS AND SERVICE

In case of failure or damage to the Grassland Combi, please contact the manufacturer. The contact data can be found in chapter 4.

# 11 INFORMATION ON NATURE CONSERVATION AND ENVIRONMENTAL PROTECTION

### Reduction of noise pollution during use

Any loose parts (e.g. chains) should be attached to prevent unnecessary noise.

### Energy-efficient use

The tines of the Grassland Combi should not penetrate into the soil deeper than necessary. By doing so, the towing vehicle is not unnecessarily strained and fuel can be saved.

### Recyclable raw materials during disposal

Many parts of the Grassland Combi are made of steel or spring steel (such as the frame, tine section, tines, ...) and can be accepted and recycled by a waste disposal plant.

## 12 TECHNICAL DATA

<b>Type designation:</b>	<b>GK 400 M1</b>
Mode of operation:	Levelling with leaf springs with wear plate 2 rows of aggressive round spring tines Pressure-adjustable reconsolidation
Working width:	3.98 m
Transport width:	4.13 m
Dimensions (with seeder) (H x W x D):	1.71 m x 4.13 m x 1.82 m
Dimensions (without seeder) (H x W x D):	1.31 m x 4.13 m x 1.82 m
Working depth:	0 to 40 mm
Number of tines [ø12 mm / ø10 mm]:	55
Line distance:	72.5 mm
Mounting/hitch (three-point, ...):	linkage
Weight (full):	1850 kg (2030 kg)
Roller (410):	1316 kg
Roller (530):	1236 kg
Roller (390):	870 kg
Harrow:	530 kg
Ground adaptation:	Swinging bearing -> Ground adaptation height of 7 cm
Trailing elements:	Cambridge roller d = 530 mm Cambridge roller d = 390 mm Toothed ring roller d = 410 mm
Minimum tractor performance:	120 PS
Special features:	All components can be used individually or in different combinations Can be separated into a front and a rear implement
Special accessories:	Lighting with warning signs Mounting device for seeder Platform kit for harrow Dispersion plate installation on the harrow Sensor set GPSa + top link linkage sensor
Combination options:	Pneumatic seeder 120-500 with electric and hydraulic fan

## 13 HYDRAULIC DIAGRAM

Hydraulic roller adjustment of the GK 400 M1:

- 1: Control unit
- 2: Hydraulic couplings
- 3: Hydraulic roller cylinder
- 4: Hydraulic locking block

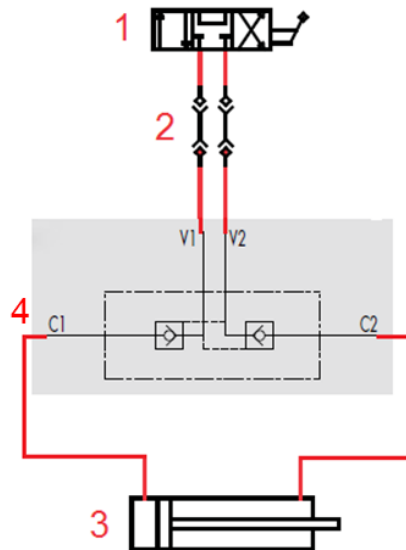

Fig. 18

## 14 ROAD TRANSPORT

### 14.1 TRANSPORT ON PUBLIC ROADS (GENERAL INFORMATION)

- Make sure than none of the safety splints or similar were lost during operation.
- Comply with the road traffic regulations of your country's legislation.
- Only relieve the hydraulic hoses at home by putting the tractor control unit into float position.
- The holder for the warning sign with lighting (optional equipment) is mounted on the carrier for the roller and should be positioned vertically to the road.
- On the implement side, the top link must be firmly attached - never in the elongated slot of the implement.
- If you are using a ground wheel for the pneumatic spreader with a side bracket, please remove it and hang it on the frame so that the transport width of 3 m is maintained.
- After field operation, the roller of the GK 400 M1 must be cleaned to prevent soil residues adhering to the roller from falling on the road.
- Protection covers and warning devices of hazards in the road traffic must be checked before every use.

### 14.2 TRANSPORT ON PUBLIC ROADS (MOST IMPORTANT SPECIFICATIONS)

- The axle load and the total weight of the towing vehicle may not be exceeded.
- The mounted implement must be identified with warning signs or stickers with red and white slanted lines (according to DIN, ÖNORM or the respective country-specific STANDARDS).
- Any part posing a traffic hazard or dangerous parts must be covered and additionally identified with warning signs or stickers. Warning signs or stickers should be visible at a height of max. 150 cm above the road when driving.
- Lighting equipment of the towing vehicle may not be hidden by the implement, otherwise they must be replicated on the mounted implement.
- The steering capacity of the tractor must not be impeded or reduced by the mounted implement!
- If the transport width of the GK 400 does not comply with the road traffic regulations of the respective country of the operator, the GK 400 must be transported on a flatbed trailer.

## 14.3 CALCULATION OF THE WEIGHT RATIOS

If you want to drive with an implement that is attached to the 3-point linkage, you must ensure that you do not exceed the tractor's maximum permissible total load, the permissible axle loads and tyre load capacities with the mounted implement.

The front axle of the tractor must be loaded with at least 20 % of the net weight of the tractor.

All of these values can be determined with this calculation:

Specifications:

- $T_L$  Tractor net weight
- $T_V$  Front axle load of the empty tractor
- $T_H$  Rear axle load of the empty tractor
- $G_H$  Total weight of the rear-mounted implement
- $G_V$  Total weight of the front-mounted implement
- $a$  Distance from the centre of gravity of the front-mounted implement to the centre of the front axle
- $b$  Wheelbase of the tractor
- $c$  Distance from the centre of the rear axle to the centre of the lower link ball
- $d$  Distance from the centre of the lower link ball to the centre of gravity of the rear-mounted implement

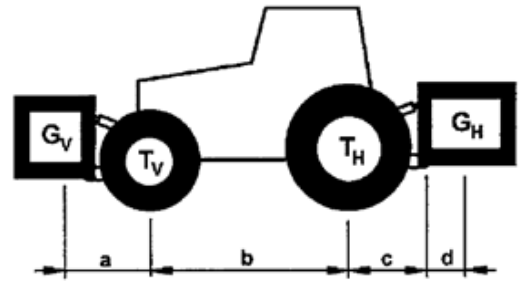

Fig. 19

### Weight calculations

1. Calculation of the minimum front ballast for rear-mounted implements  $G_V \text{ min}$ :

$$G_{V \text{ min}} = \frac{G_H \cdot (c + d) - T_V \cdot b + 0,2 \cdot T_L \cdot b}{a + b}$$

This result is entered in the table under Point 14.3.1.

2. Calculation of the minimum rear ballast for front-mounted implements  $G_H \text{ min}$ :

$$G_{H \text{ min}} = \frac{G_V \cdot a - T_H \cdot b + 0,45 \cdot T_L \cdot b}{b + c + d}$$

This result is also entered in the table under Point 14.3.1.

3. Calculation of the actual front axle load  $T_V \text{ tat}$ :

If the required minimum front ballast ( $G_V \text{ min}$ ) is not reached with the front-mounted implement ( $G_V$ ), the weight of the front-mounted implement must be increased to the weight of the minimum front ballast!

$$T_{V \text{ tat}} = \frac{G_V \cdot (a + b) + T_V \cdot b - G_H \cdot (c + d)}{b}$$

Now enter the calculated actual front axle load and the permissible front axle load of the tractor specified in the tractor operating manual in the table under Point 14.3.1.

4. Calculation of the actual total weight  $G_{\text{tat}}$ :

If the required minimum rear ballast ( $G_H$ ) is not reached with the rear-mounted implement ( $G_H \text{ min}$ ), the weight of the rear-mounted implement must be increased to the weight of the minimum rear ballast!

$$G_{\text{tat}} = G_V + T_L + G_H$$

Now enter the calculated total weight and the permissible total weight specified in the tractor operating manual in the table under Point 14.3.1.

5. Calculation of the actual rear axle load  $T_H \text{ tat}$ :

$$T_{H \text{ tat}} = G_{\text{tat}} - T_{V \text{ tat}}$$

Now enter the calculated actual rear axle load and the permissible rear axle load specified in the tractor operating manual in the table under Point 14.3.1.

**6. Tyre load capacity:**

Enter the doubled value (two tyres) for the permissible tyre load capacity (see e.g. tyre manufacturer documents) in the table under Point 14.3.1.

**14.3.1 TABLE FOR THE WEIGHT RATIOS**

	Actual value acc. to calculation		Permissible value acc. to operating manual		Double the permissible tyre load capacity (2 tyres)
Minimum ballast front/rear	kg				
Total weight	kg	≤	kg	≤	kg
Front axle load	kg	≤	kg	≤	kg
Rear axle load	kg	≤	kg	≤	kg

**CAUTION!**

The minimum ballast must be attached to the tractor as a mounted implement or ballast weight!  
The calculated values may not be higher than the permissible values!

**15 LIGHTING CIRCUIT DIAGRAM**

- R Right
- L Left
- 1 12 V plug, 7-pin
- 2 Rear light, right
- 2.1 Turn signal
- 2.2 Rear light
- 2.3 Brake light
- 3 Rear light, left
- 3.1 Brake light
- 3.2 Rear light
- 3.3 Turn signal

**Plug and cable assignment:**

No.	Desig.	Colour	Function
1	L	yellow	Turn signal, left
2	54g	---	----
3	31	White	Ground
4	R	Green	Turn signal, white
5	85R	brown	Rear light, right
6	54	red	Brake light
7	58L	black	Rear light, left

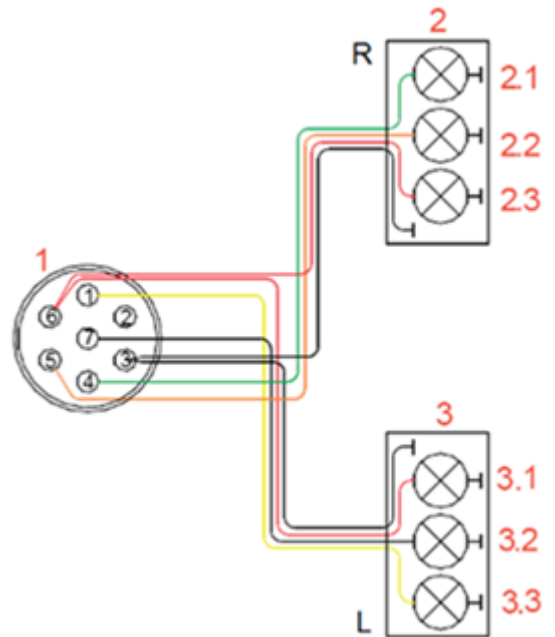

Fig. 20

## 16 DECOMMISSIONING, STORAGE AND DISPOSAL

### 16.1 DECOMMISSIONING THE IMPLEMENT

To ensure that the implement remains fully functional, even if it is out of operation for longer periods of time, it is important to take precautions for storage: To do so, observe Point 16.2.

### 16.2 STORAGE OF THE IMPLEMENT

- The implement must be stored in a dry place protected from weather conditions to ensure that it remains functional even if it is stored for a longer period of time.
- The parking surface must be suitable for parking the implement. The ground must be firm and level, so that the stands do not sink in and the Grassland Combi does not roll away.
- To ensure safe parking of the implement, lower the stands at the rear of the Grassland Combi.
- Make sure that the tines do not touch the ground in the process to prevent damage to the tines.
- The stands must be secured with a spring cotter on the pin to prevent accidental loosening.
- Secure the implement against unintentional rolling away.
- Then the hydraulic hoses to the tractor must be depressurised and uncoupled.
- Nothing may be deposited or stored on the implement.
- The Grassland Combi must always be parked and stored in a secure area. An unauthorised operation has to be prevented.

### 16.3 DISPOSAL

Disposal of the implement must be performed according to the local disposal regulations for implements.

### 16.4 CROP CULTIVATION TIPS WHEN USING THE GK 400 M1

Seedbed preparation is always required before reseeding. This procedure is optimally accomplished with the grassland combination Grassland Combi GK 400 M1 with 2 tine rows. Together with the reconsolidation with a roller, three working procedures are accomplished in one field pass.

With its thorough and effective mode of action, the GK 400 M1 can be optimally integrated in your overall management concept.

The goal of your concept will be to improve yields and to increase the valuable grasses.

Other effects of the GK 400 M1, like

- Soil aeration
- Regulation of the water balance
- Incorporation of the seed
- Reconsolidation
- Pressing down the seed and therefore
- Promoting tillering

make a significant contribution to the formation of good crops.

The success of weed control without chemicals and high yields, however, depend very strongly on you, as you will be required to closely observe the processes in your soil.

Reseeding of grassland is theoretically possible during the entire frost- and snow-free period. Gaps in the crops should already be reseeded in the spring to prevent weed competition. As a matter of principle, you should reseed more frequently and therefore work less aggressively and reduce the seed quantity.

Reseeding can be performed in the spring as soon as the soil has warmed up a little. The soil must have good trafficability, i.e. the seed should not be "smeared in".



Reseeding in the spring has the advantage that the spring humidity and the disturbed soil can be used as a seedbed. However, despite good germination, the grass can dry out during a summer drought, and the pressure of the old sod is greater in the spring due to the stronger growth spurt.

With the GK 400 M1, we counteract this disadvantage with a roller that presses down the seed and therefore improves soil contact. This allows the seed to germinate more rapidly and the risk of desiccation is reduced.

The optimal strength and depth setting, forward speed and the adjustment of the tines and seeding rate must be set with your understanding of the correlations between the soil properties and weather conditions, which can vary greatly in different regions.

## 17 ACCESSORIES

### 17.1 LIGHTING WITH WARNING SIGNS (ON BOTH SIDES)

Is required when the GK is transported on public roads.

Order number:

06001-2-021



Fig. 21

### 17.2 PLATFORM KIT FOR THE HARROW

For easier maintenance of the Pneumatic Seeder – if equipped. Please note that the Pneumatic Seeder must be mounted in compliance with the standards.

Order number:

06008-2-015



Fig. 22

## 17.3 ACCESSORIES KIT FOR DISPERSION PLATE INSTALLATION FOR THE HARROW

This is used to mount the dispersion plates on the harrow.

Order number:  
06023-2-030



Fig. 23

## 17.4 PNEUMATIC SEEDER MOUNTING KIT FOR THE HARROW

Is required to mount a Pneumatic Seeder on the harrow. Please note that the Pneumatic Seeder must be mounted in compliance with the standards.

Order number:  
06008-2-033



Fig. 24

## 17.5 MULTI-METERING SYSTEM MOUNTING KIT FOR THE HARROW

Is required to mount a Multi-Metering System on the harrow. Please note that the Multi-Metering System must be mounted in compliance with the standards.

Order number:  
06008-2-031



Fig. 25

## 17.6 SENSOR SET - GPSA + LINKAGE SENSOR TOP LINK

In combination with a Pneumatic Seeder, these sensors

- can be used with ground speed-dependent seed application
- to automatically stop the seeding shaft when the implement is lifted at the headlands.

Order number:  
00300-2-053



Fig. 26



Fig. 27

## 18 SPARE PARTS

You have the option to order your required spare parts directly through our online spare parts catalogue. To do so, scan the QR code with your smartphone - you will be taken directly to our online spare parts catalogue. Please keep your product number / serial number at hand.



You can also view our online spare parts catalogue on our website [www.apv.at](http://www.apv.at) in the Service area.

If you have any questions regarding spare parts or your order, our Customer Service (see point 4 for contact data) is also happy to assist you.

## 19 INDEX

Accessories .....	25	Operating Manual .....	11, 12, 22, 23
Accident prevention regulations .....	7	Permissible axle loads .....	22
Aggressiveness adjustment .....	17	Plug and cable assignment .....	23
Air pressure .....	12	Recyclable raw materials .....	19
Bearing .....	20, 24	Reduction of noise pollution .....	19
Care .....	18	Repairs and service .....	19
Changing the tines .....	19	Road transport .....	21
Cropping tips .....	24	Safety information .....	7
Decommissioning .....	24	Safety-related instructions .....	7
Disposal .....	19, 24	Seeders .....	10
EC Declaration of Conformity .....	4, 5	Service .....	6
Energy-efficient use .....	19	Shear-off safety .....	17
Forward speed .....	16	Spare parts .....	27
Hydraulic diagram .....	21	Steering and braking capacity .....	12
Hydraulic system .....	9	Technical data .....	20
Identification of the implement .....	6	Tine safety .....	19
Information signs .....	11	Type plate .....	6
Intended use .....	7	Tyre load capacity of the tractor .....	22
Layout .....	16	Tyres .....	10, 23
Levelling plate .....	17	Use of individual tools .....	18
Lighting .....	20, 23	Warranty .....	6
Maintenance .....	9, 18	Warranty activation .....	7
Max. permissible total weight .....	22	Warranty claims .....	6
Mode of operation .....	16	Weight ratios .....	22
Mounted implements .....	9	Working depth .....	16, 20
Mounting on the tractor .....	12		

---

---

---

---

---

---

**APV – Technische Produkte GmbH**  
Zentrale: Dallein 15  
AT - 3753 Hötzelndorf

Tel.: +43 2913 8001  
office@apv.at  
www.apv.at

